

**PART NUMBER**  
**ESPC28, ESPC33, ESPC40**

**MODEL DESCRIPTION**

SPACEPOLE Series - Vertical Service Columns  
 &/or Horizontal Service Ducting

PART NUMBER:  
 ESPC    **XX**    -    **XX**

| LENGTH (METRES) | COLOUR                |
|-----------------|-----------------------|
| 28 = 2.8m       | BL = Black            |
| 33 = 3.3m       | NA = Natural Anodised |
| 40 = 4.0m       | OG = Opal Grey        |
|                 | OW = Off White        |

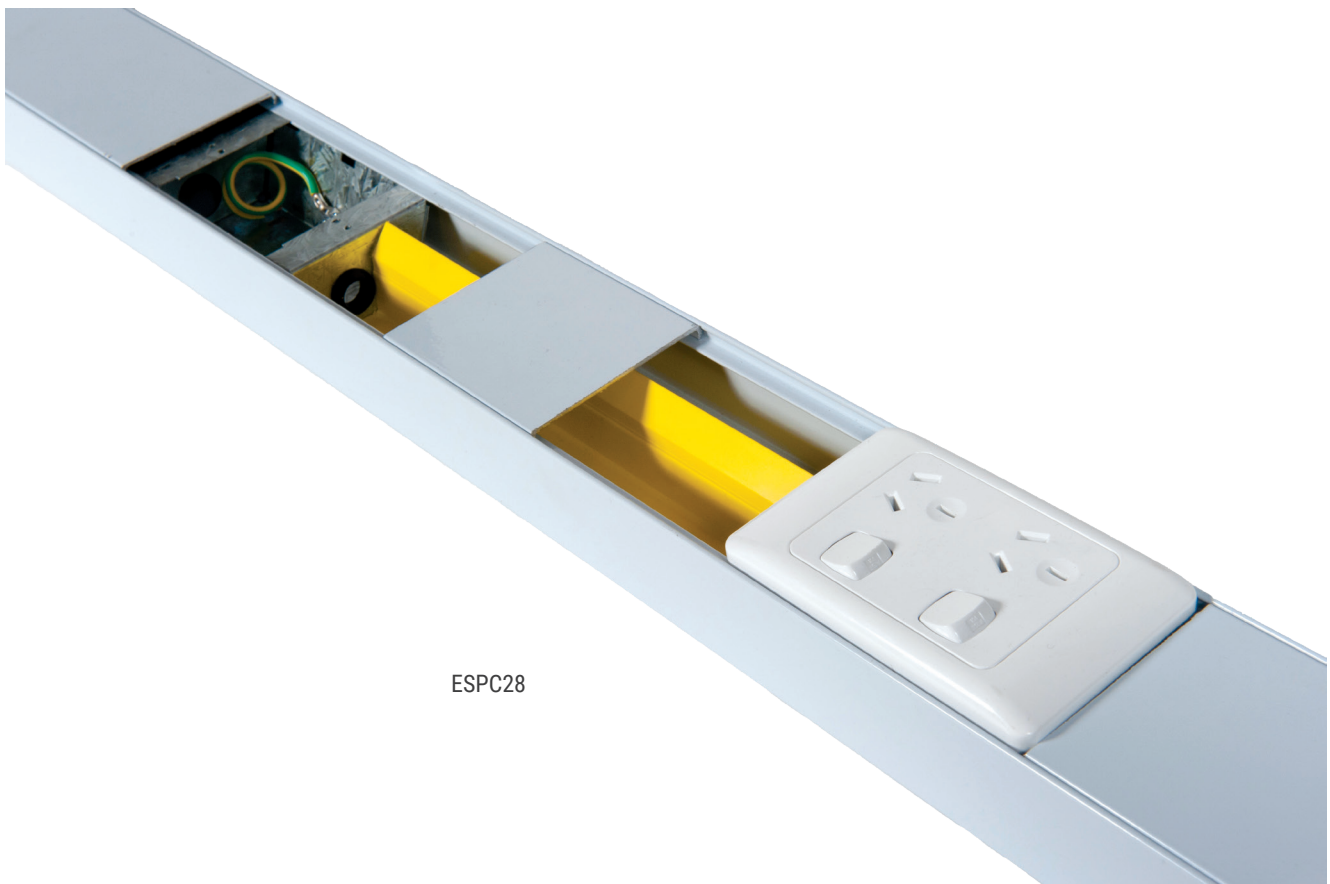

ESPC28

**TECHNICAL DATA**

|                    |  |
|--------------------|--|
| <b>PART NUMBER</b> | ESPC28, ESPC33, ESPC40   |
| <b>DESCRIPTION</b> | SPACEPOLE Series - Vertical & Horizontal Service Columns or Ducting Supplied completely boxed with floor mounting kit as well as ceiling (T-Bar) mount, and three standard wall plate accessory mounting kits (extras available) |
| <b>COLOUR</b>      | Available in either Black (BL) Natural Anodised (NA) Opal Grey (OG), Off White (OW) or any standard Powder Coated Finishes (upon request, at extra cost)   |
| <b>DIMENSIONS</b>  | <b>ESPC28:</b> W80 x D45 L2800mm, <b>ESPC33:</b> W80 x D45 L3300mm, <b>ESPC40:</b> W80 x D45 L4000mm   |

## DIMENSIONS

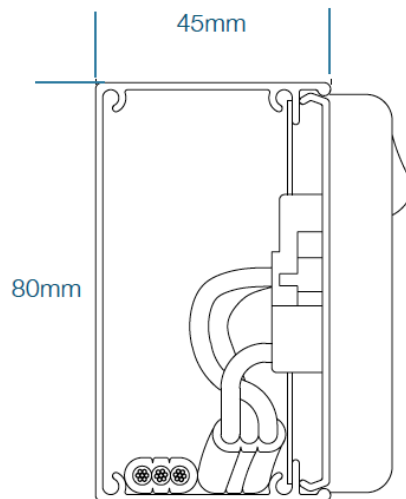

Spacepole Dimensional Cross Section  
 80 x 45mm Aluminium w Clip-In Lid

### ACCESSORIES

- ESPCMB - Accessory Mounting Box (84mm centres)
- ESPCF - Ceiling Mounting Flange
- ESPCCF2 - Double Ceiling Flange (Back to Back Mounting Cover)
- ESPCFB - Concrete/Timber Floor Mounting Kit
- ESPCCK - T-Bar Internal Ceiling Mounting Kit
- AOL45-80JP - Joining Pins (Pack of 4)
- Z21A054 - Plastic 2 Channel Divider (600mm Section)

**esco**  
 industries

THE ESCO GROUP OF COMPANIES

**esco** INDUSTRIES **MediTek**

modempak

#### ESCO INDUSTRIES

89 Egerton St (Cnr Fariola & Egerton)  
 PO Box 6193, Silverwater  
 NSW 2128 AUSTRALIA

#### MODEMPAK NZ

Unit 11/273 Neilson St, Onehunga  
 AUCKLAND 1061 NEW ZEALAND

T 1300 879 363 F 1300 879 364

customer.service@escoindustries.com.au  
 www.escoindustries.com.au

D +64 9 526 1880 Freecall 0800 663 367

customer.service@modempak.co.nz  
 www.modempak.co.nz