

PART NUMBER

CSWP1V16WH

MODEL DESCRIPTION

Comfort Switch 1 Gang, 2-Way, 16A, Vertical, White

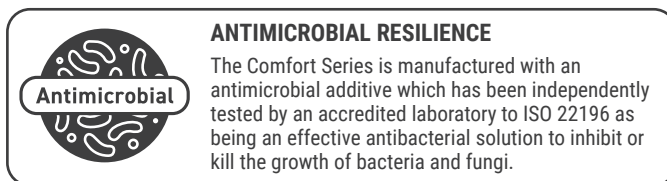

TECHNICAL DATA

PART NUMBER	CSWP1V16WH
DESCRIPTION	Comfort Switch 1 Gang, 2-Way, 16A, Vertical, White
SUPPLY VOLTAGE	230-240Va.c.
CURRENT RATING	16A
COLOUR	White
MOUNTING CENTRE	84mm
PLATE SIZE	Standard
SWITCH SIZE	48.5mm x 48.5mm
COMPLIANCE	AS/NZS 3133, ISO 22196, AS 1428.1 - Design for access and mobility, Livable Housing Design Guidelines – Switches & Powerpoints (Platinum Level)

DIMENSIONS

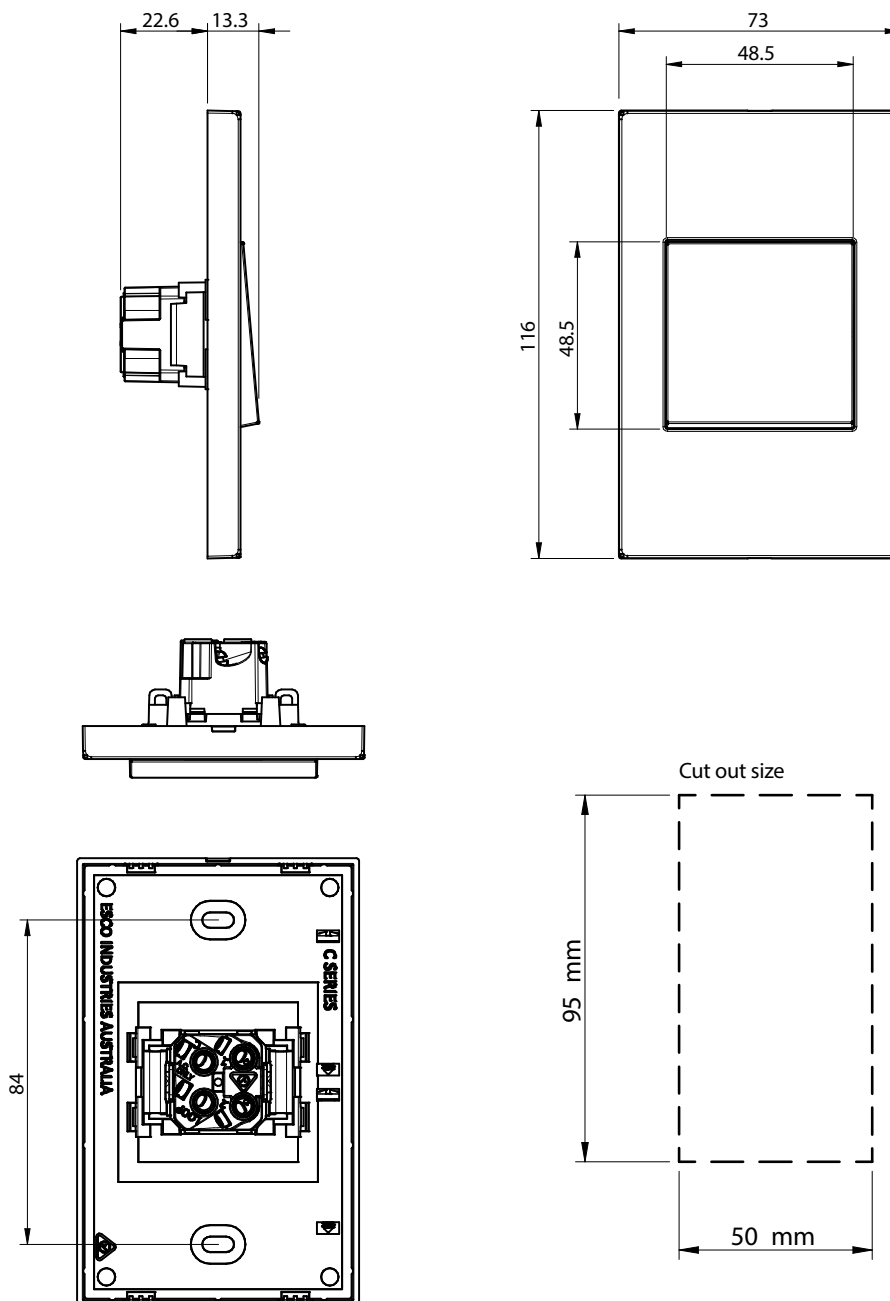

esco
industries

THE ESCO GROUP OF COMPANIES

esco industries MASRAP **MediTek**

modempak

ESCO INDUSTRIES

89 Egerton St (Cnr Fariola & Egerton)
PO Box 6193, Silverwater
NSW 2128 AUSTRALIA

T 1300 879 363 F 1300 879 364
customer.service@escoindustries.com.au
www.escoindustries.com.au

MODEMPAK NZ

Unit 11/273 Neilson St, Onehunga
AUCKLAND 1061 NEW ZEALAND

D +64 9 526 1880 Freecall 0800 663 367
customer.service@modempak.co.nz
www.modempak.co.nz

PART NUMBER

CSWP1VL16WH

MODEL DESCRIPTION

Comfort Switch 1 Gang, 2-Way, with red LED 'ON' indicator, 16A, Vertical, White

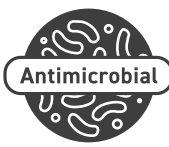

ANTIMICROBIAL RESILIENCE

The Comfort Series is manufactured with an antimicrobial additive which has been independently tested by an accredited laboratory to ISO 22196 as being an effective antibacterial solution to inhibit or kill the growth of bacteria and fungi.



TECHNICAL DATA

PART NUMBER	CSWP1VL16WH
DESCRIPTION	Comfort Switch 1 Gang, 2-Way, with red LED 'ON' indicator, 16A, Vertical, White
SUPPLY VOLTAGE	230-240Va.c.
CURRENT RATING	16A
COLOUR	White
MOUNTING CENTRE	84mm
PLATE SIZE	Standard
SWITCH SIZE	48.5mm x 48.5mm
COMPLIANCE	AS/NZS 3133, ISO 22196, AS 1428.1 - Design for access and mobility, Livable Housing Design Guidelines – Switches & Powerpoints (Platinum Level)

DIMENSIONS

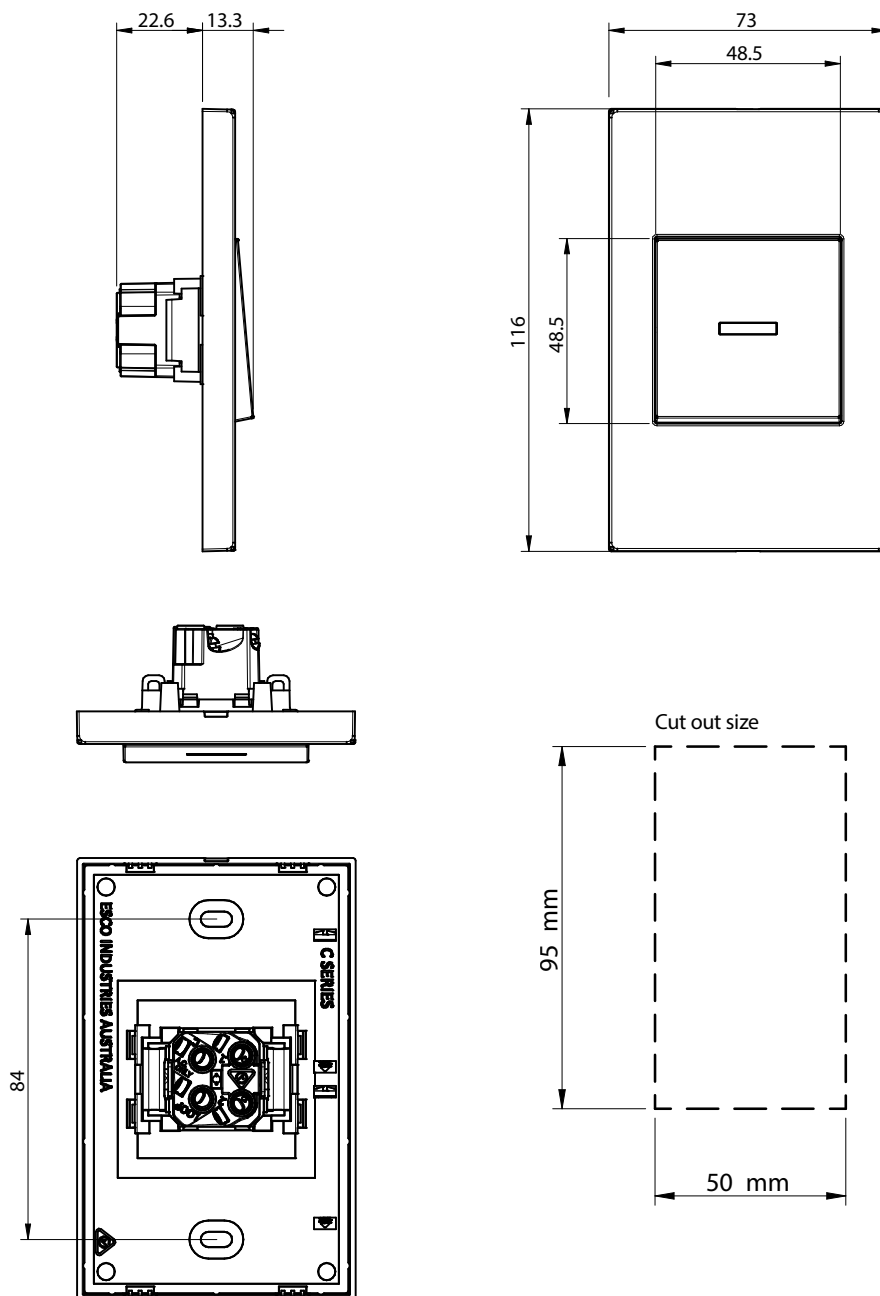

esco
industries

THE ESCO GROUP OF COMPANIES

esco industries MASRAP **MediTek**

modempak

ESCO INDUSTRIES

89 Egerton St (Cnr Fariola & Egerton)
PO Box 6193, Silverwater
NSW 2128 AUSTRALIA

T 1300 879 363 **F** 1300 879 364
customer.service@escoindustries.com.au
www.escoindustries.com.au

MODEMPAK NZ

Unit 11/273 Neilson St, Onehunga
AUCKLAND 1061 NEW ZEALAND

D +64 9 526 1880 **Freecall** 0800 663 367
customer.service@modempak.co.nz
www.modempak.co.nz

PART NUMBER

CSWP2V16WH

MODEL DESCRIPTION

Comfort Switch 2 Gang, 2-Way, 16A, Vertical, White

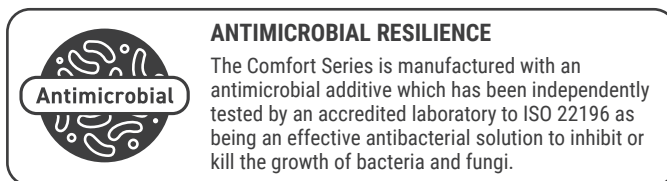

TECHNICAL DATA

PART NUMBER	CSWP2V16WH
DESCRIPTION	Comfort Switch 2 Gang, 2-Way, 16A, Vertical, White
SUPPLY VOLTAGE	230-240Va.c.
CURRENT RATING	16A
COLOUR	White
MOUNTING CENTRE	84mm
PLATE SIZE	Standard
SWITCH SIZE	48.5mm x 48.5mm
COMPLIANCE	AS/NZS 3133, ISO 22196, AS 1428.1 - Design for access and mobility, Livable Housing Design Guidelines – Switches & Powerpoints (Platinum Level)

DIMENSIONS

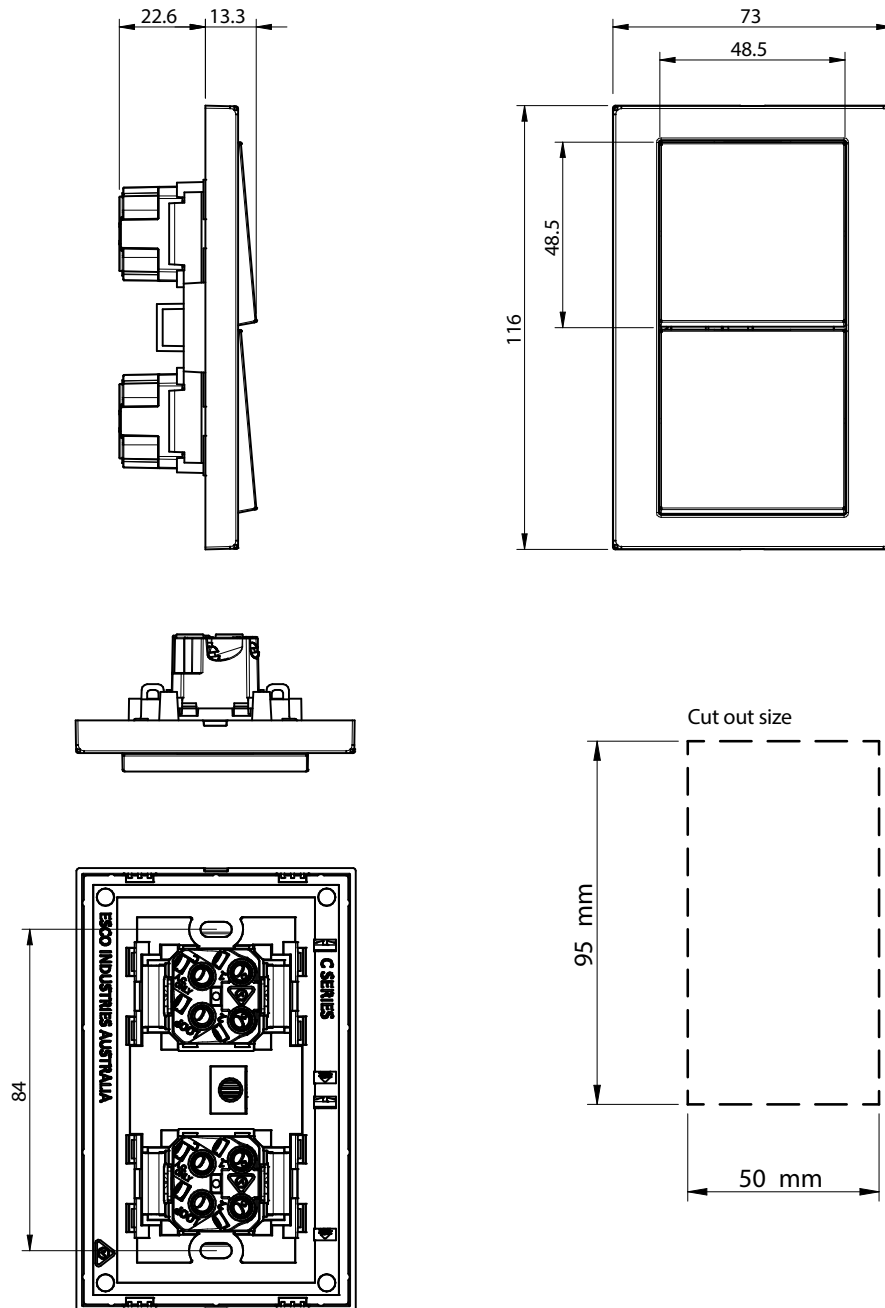

esco
industries

ESCO INDUSTRIES
89 Egerton St (Cnr Fariola & Egerton)
PO Box 6193, Silverwater
NSW 2128 AUSTRALIA

T 1300 879 363 **F** 1300 879 364
customer.service@escoindustries.com.au
www.escoindustries.com.au

THE ESCO GROUP OF COMPANIES

esco industries MASRAP **MediTek**

modempak

MODEMPAK NZ
Unit 11/273 Neilson St, Onehunga
AUCKLAND 1061 NEW ZEALAND

D +64 9 526 1880 **Freecall** 0800 663 367
customer.service@modempak.co.nz
www.modempak.co.nz

PART NUMBER

CSWP2VL16WH

MODEL DESCRIPTION

Comfort Switch 2 Gang, 2-Way, with red LED 'ON' indicator, 16A, Vertical, White



ANTIMICROBIAL RESILIENCE

The Comfort Series is manufactured with an antimicrobial additive which has been independently tested by an accredited laboratory to ISO 22196 as being an effective antibacterial solution to inhibit or kill the growth of bacteria and fungi.



TECHNICAL DATA

PART NUMBER	CSWP2VL16WH
DESCRIPTION	Comfort Switch 2 Gang, 2-Way, with red LED 'ON' indicator, 16A, Vertical, White
SUPPLY VOLTAGE	230-240Va.c.
CURRENT RATING	16A
COLOUR	White
MOUNTING CENTRE	84mm
PLATE SIZE	Standard
SWITCH SIZE	48.5mm x 48.5mm
COMPLIANCE	AS/NZS 3133, ISO 22196, AS 1428.1 - Design for access and mobility, Livable Housing Design Guidelines – Switches & Powerpoints (Platinum Level)

DIMENSIONS

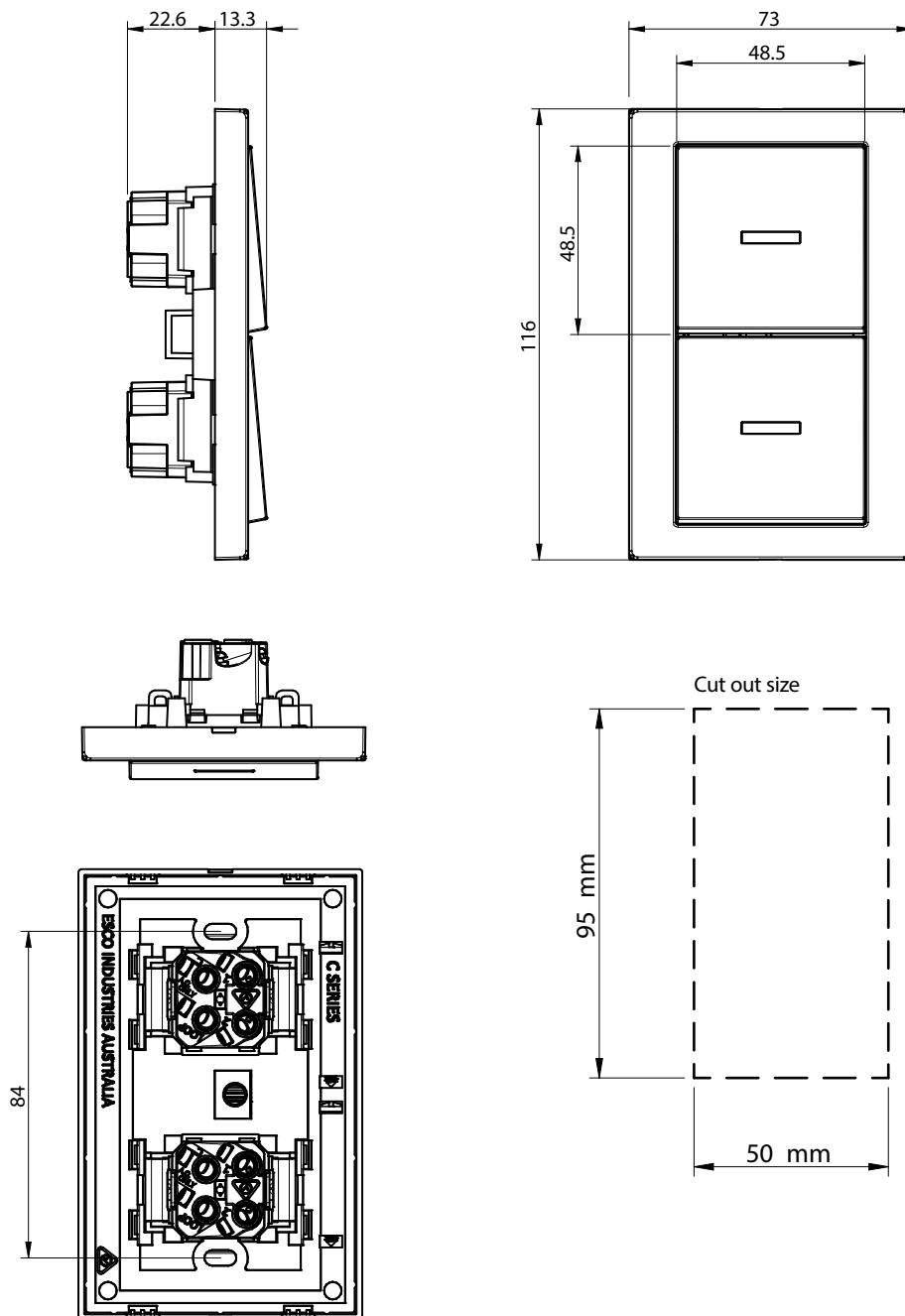

esco
industries

ESCO INDUSTRIES
 89 Egerton St (Cnr Fariola & Egerton)
 PO Box 6193, Silverwater
 NSW 2128 AUSTRALIA

T 1300 879 363 **F** 1300 879 364
 customer.service@escoindustries.com.au
 www.escoindustries.com.au

THE ESCO GROUP OF COMPANIES

esco MASRAP **MediTek**
 industries

modempak

MODEMPAK NZ
 Unit 11/273 Neilson St, Onehunga
 AUCKLAND 1061 NEW ZEALAND

D +64 9 526 1880 **Freecall** 0800 663 367
 customer.service@modempak.co.nz
 www.modempak.co.nz

PART NUMBER

CSWP116WH

MODEL DESCRIPTION

Comfort Switch 1 Gang, 2-Way, 16A, White



ANTIMICROBIAL RESILIENCE

The Comfort Series is manufactured with an antimicrobial additive which has been independently tested by an accredited laboratory to ISO 22196 as being an effective antibacterial solution to inhibit or kill the growth of bacteria and fungi.



TECHNICAL DATA

PART NUMBER	CSWP116WH
DESCRIPTION	Comfort Switch 1 Gang, 2-Way, 16A, White
SUPPLY VOLTAGE	230-240Va.c.
CURRENT RATING	16A
COLOUR	White
MOUNTING CENTRE	84mm
PLATE SIZE	Standard
SWITCH SIZE	48.5mm x 48.5mm
COMPLIANCE	AS/NZS 3133, ISO 22196, AS 1428.1 - Design for access and mobility, Livable Housing Design Guidelines – Switches & Powerpoints (Platinum Level)

DIMENSIONS

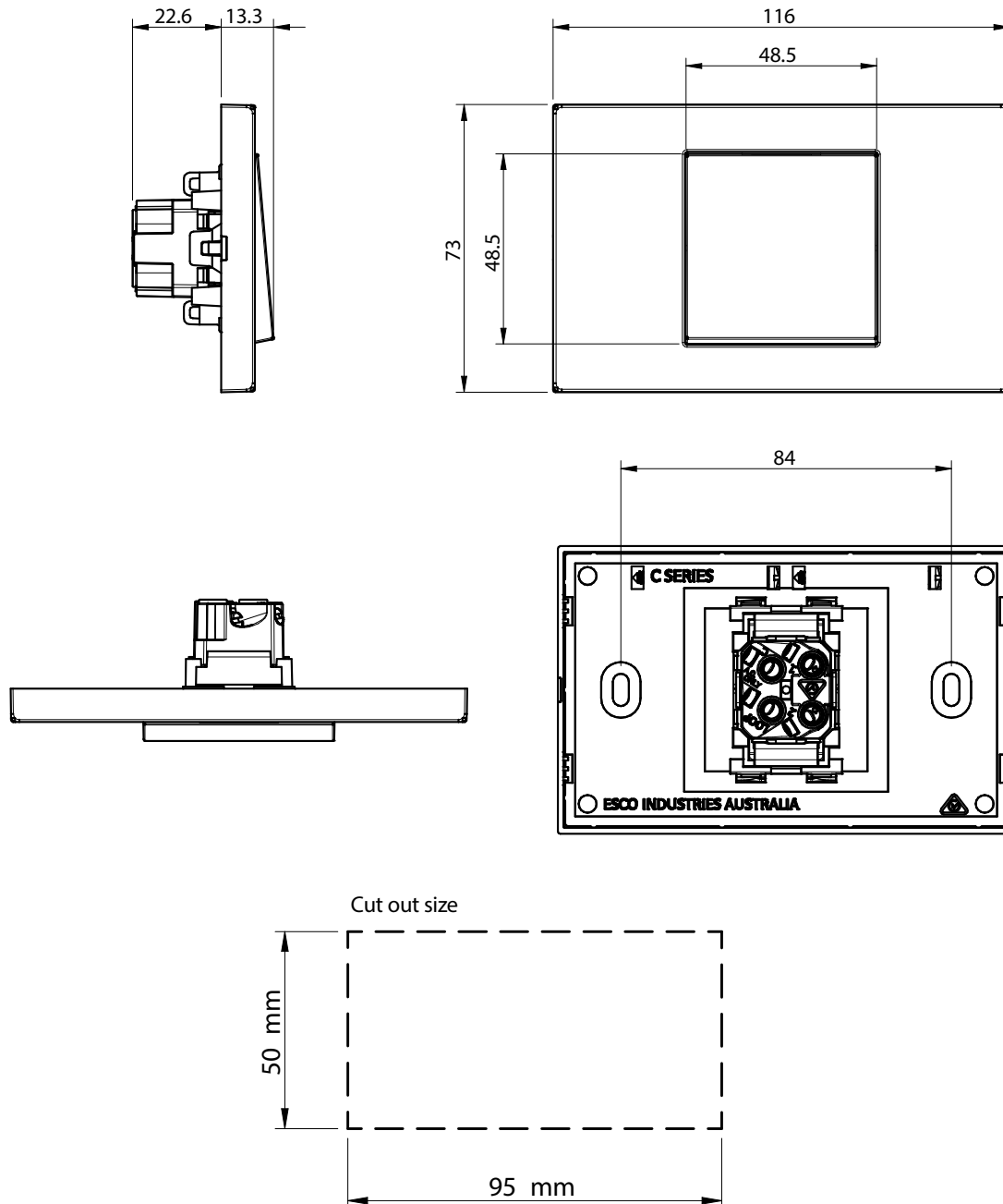

PART NUMBER

CSWP1L16WH

MODEL DESCRIPTION

Comfort Switch 1 Gang, 2-Way, with red LED "ON" indicator, 16A, White

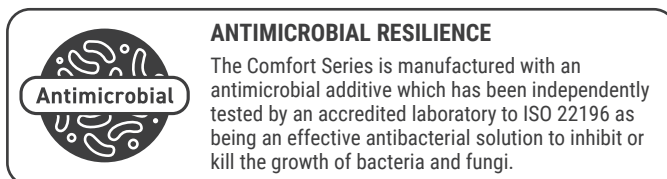

TECHNICAL DATA

PART NUMBER	CSWP1L16WH
DESCRIPTION	Comfort Switch 1 Gang, 2-Way, with red LED "ON" indicator, 16A, White
SUPPLY VOLTAGE	230-240Va.c.
CURRENT RATING	16A
COLOUR	White
MOUNTING CENTRE	84mm
PLATE SIZE	Standard
SWITCH SIZE	48.5mm x 48.5mm
COMPLIANCE	AS/NZS 3133, ISO 22196, AS 1428.1 - Design for access and mobility, Livable Housing Design Guidelines – Switches & Powerpoints (Platinum Level)

DIMENSIONS

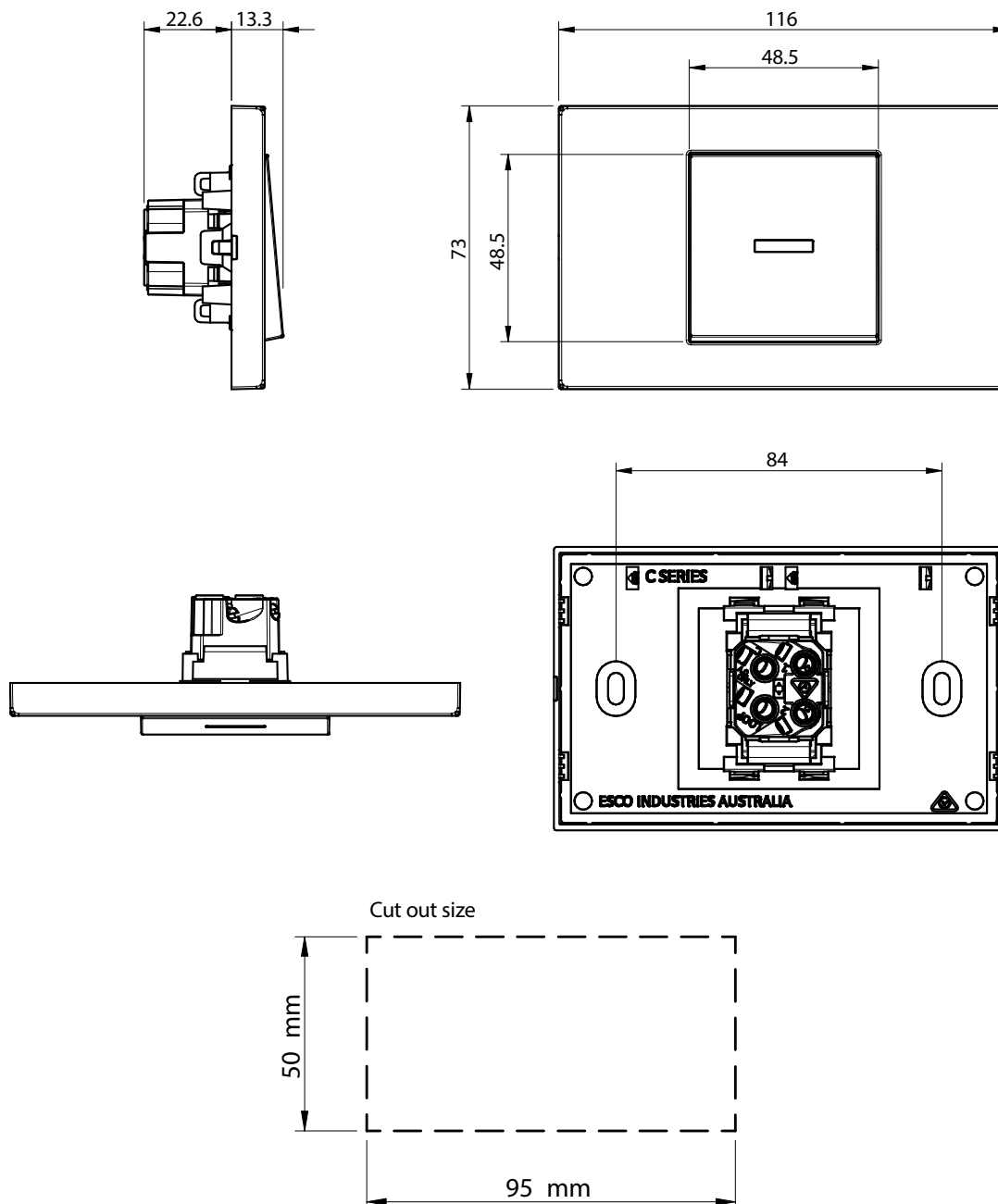

esco
industries

THE ESCO GROUP OF COMPANIES

esco industries MASRAP **MediTek**

modempak

ESCO INDUSTRIES

89 Egerton St (Cnr Fariola & Egerton)
PO Box 6193, Silverwater
NSW 2128 AUSTRALIA

T 1300 879 363 F 1300 879 364
customer.service@escoindustries.com.au
www.escoindustries.com.au

MODEMPAK NZ

Unit 11/273 Neilson St, Onehunga
AUCKLAND 1061 NEW ZEALAND

D +64 9 526 1880 Freecall 0800 663 367
customer.service@modempak.co.nz
www.modempak.co.nz

PART NUMBER

CSWP216WH

MODEL DESCRIPTION

Comfort Switch 2 Gang, 2-Way, 16A, White

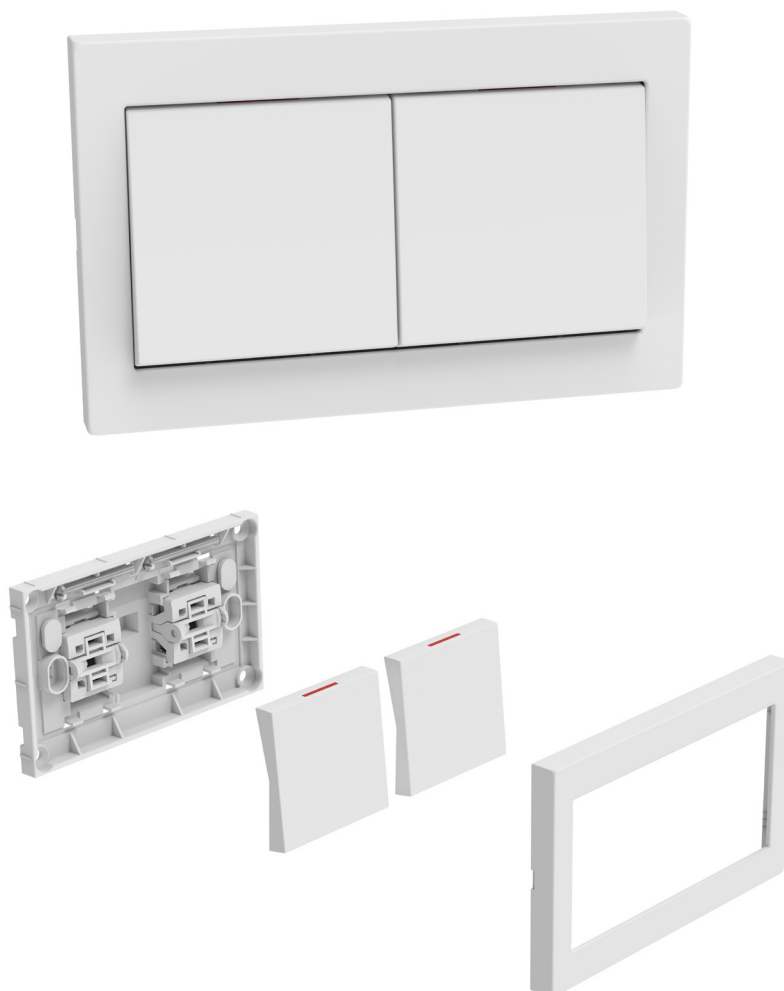
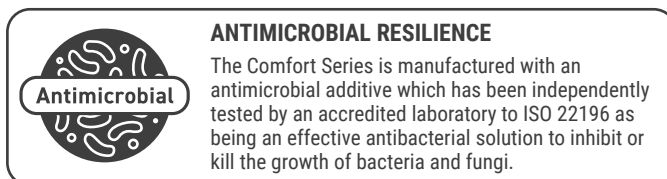

TECHNICAL DATA

PART NUMBER	CSWP216WH
DESCRIPTION	Comfort Switch 2 Gang, 2-Way, 16A, White
SUPPLY VOLTAGE	230-240Va.c.
CURRENT RATING	16A
COLOUR	White
MOUNTING CENTRE	84mm
PLATE SIZE	Standard
SWITCH SIZE	48.5mm x 48.5mm
COMPLIANCE	AS/NZS 3133, ISO 22196, AS 1428.1 - Design for access and mobility, Livable Housing Design Guidelines – Switches & Powerpoints (Platinum Level)

DIMENSIONS

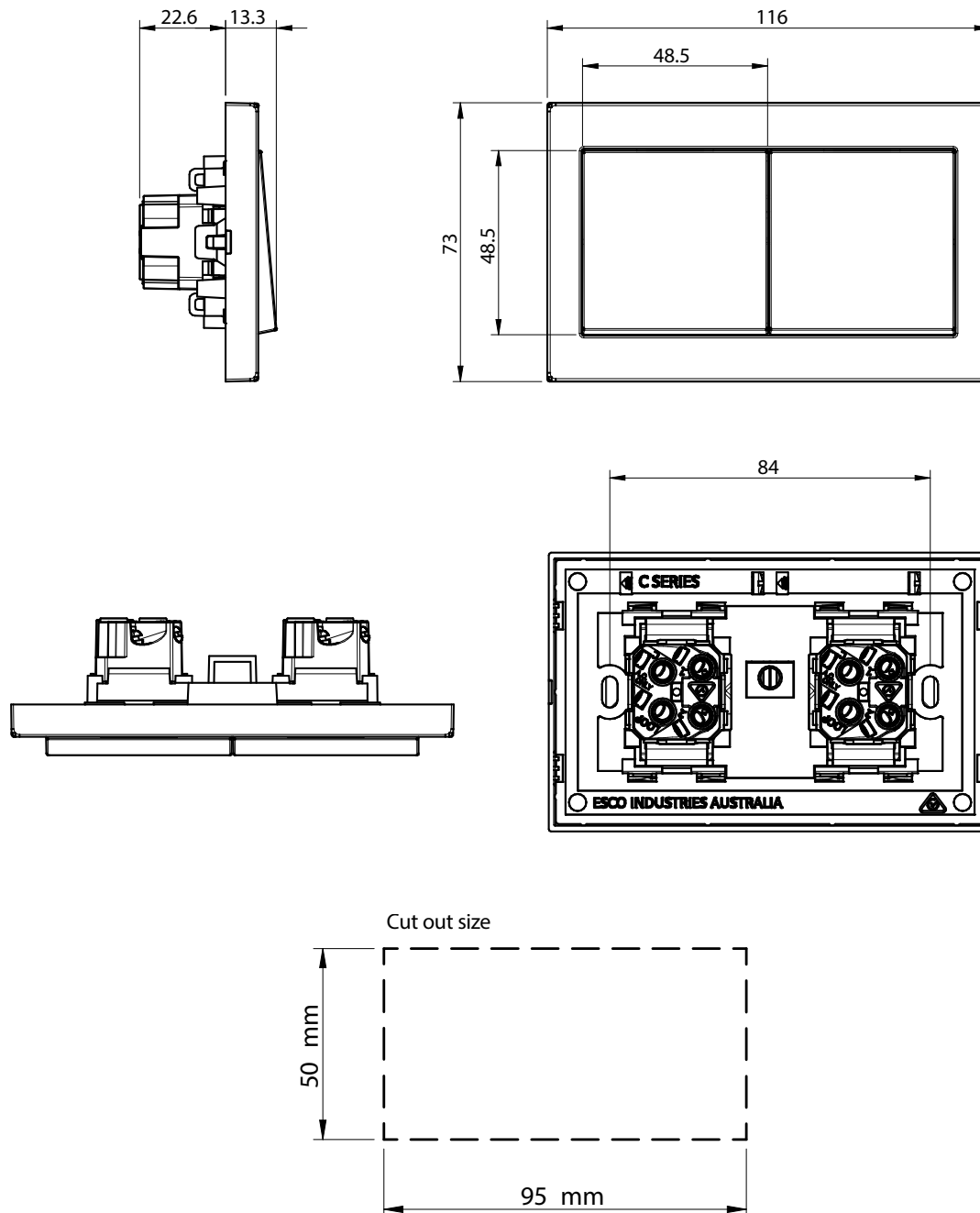

PART NUMBER

CSWP2L16WH

MODEL DESCRIPTION

Comfort Switch 2 Gang, 2-Way, with red LED "ON" indicator, 16A, White

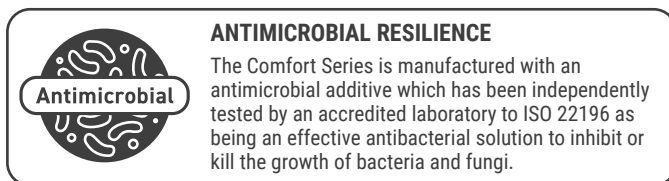

TECHNICAL DATA

PART NUMBER	CSWP2L16WH
DESCRIPTION	Comfort Switch 2 Gang, 2-Way, with red LED "ON" indicator, 16A, White
SUPPLY VOLTAGE	230-240Va.c.
CURRENT RATING	16A
COLOUR	White
MOUNTING CENTRE	84mm
PLATE SIZE	Standard
SWITCH SIZE	48.5mm x 48.5mm
COMPLIANCE	AS/NZS 3133, ISO 22196, AS 1428.1 - Design for access and mobility, Livable Housing Design Guidelines – Switches & Powerpoints (Platinum Level)

DIMENSIONS

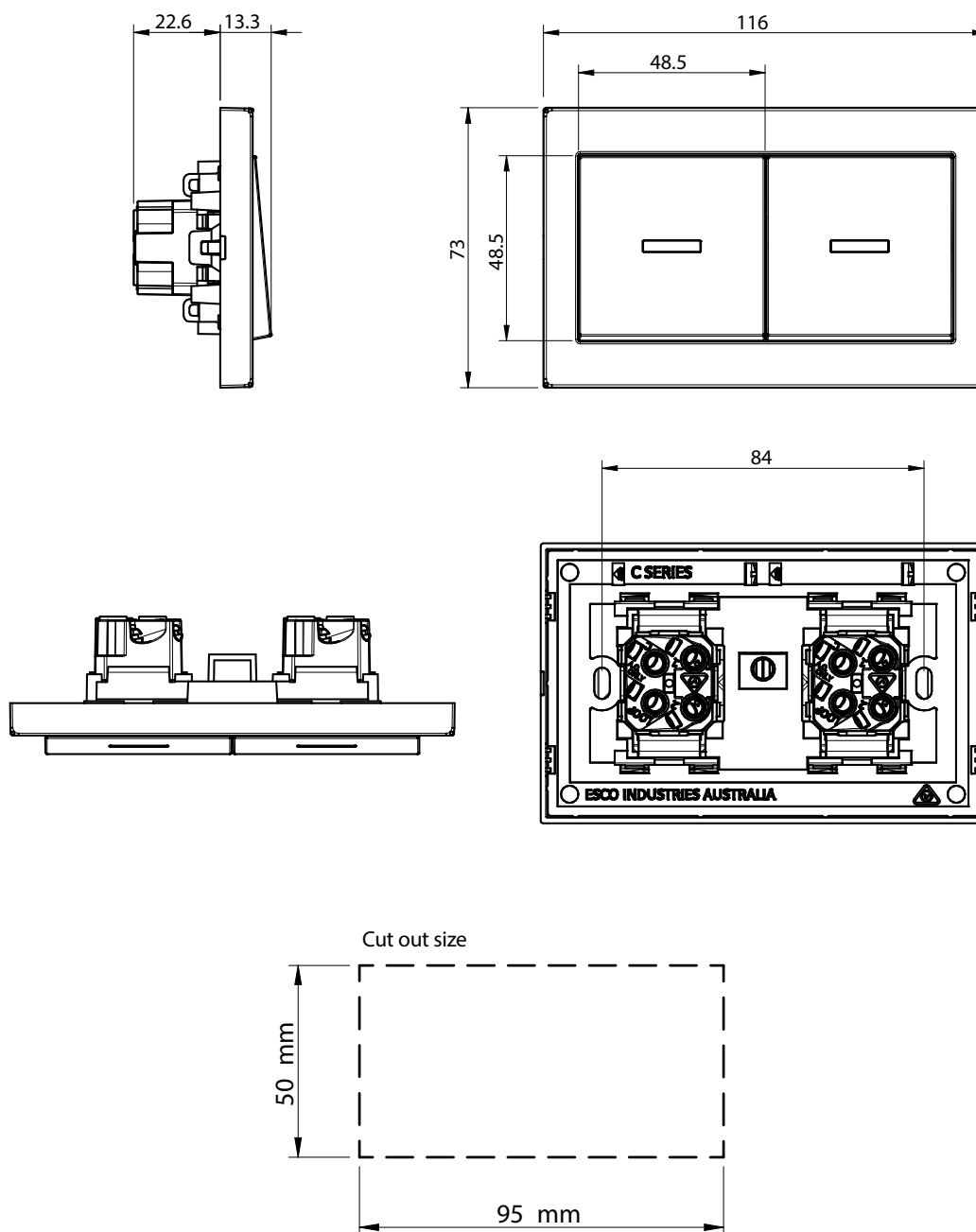

PART NUMBER

CSWP316WH

MODEL DESCRIPTION

Comfort Switch 3 Gang, 2-Way, 16A, White

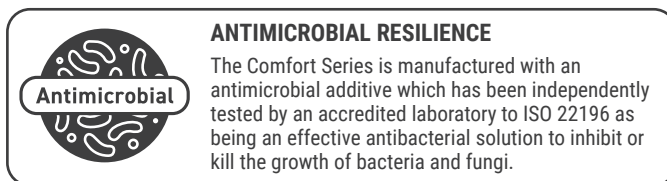

TECHNICAL DATA

PART NUMBER	CSWP316WH
DESCRIPTION	Comfort Switch 3 Gang, 2-Way, 16A, White
SUPPLY VOLTAGE	230-240Va.c.
CURRENT RATING	16A
COLOUR	White
MOUNTING CENTRE	84mm
PLATE SIZE	Standard
SWITCH SIZE	32mm x 48.5mm
COMPLIANCE	AS/NZS 3133, ISO 22196, AS 1428.1 - Design for access and mobility

DIMENSIONS

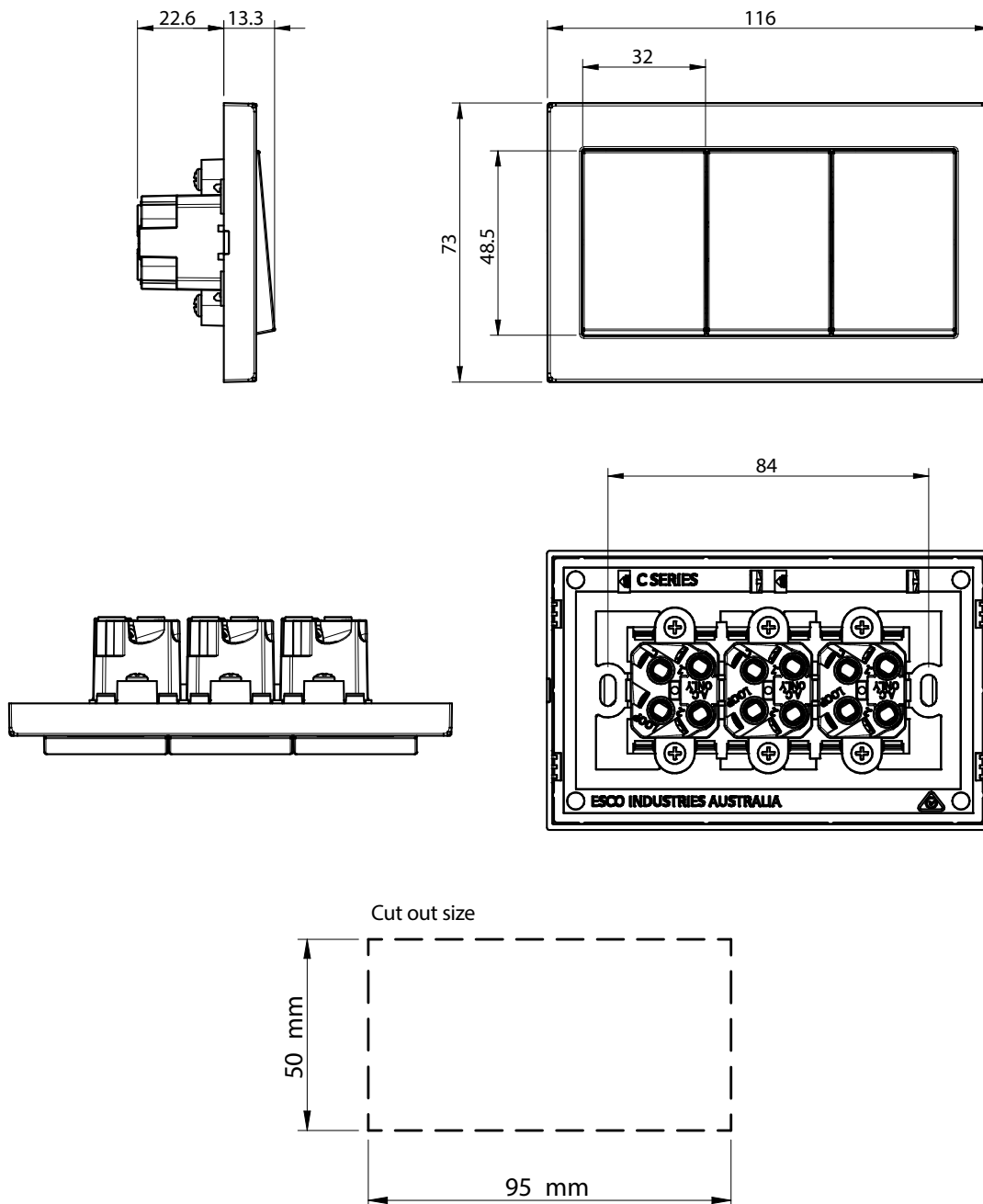

PART NUMBER

CSWP3L16WH

MODEL DESCRIPTION

Comfort Switch 3 Gang, 2-Way, with red LED "ON" indicator, 16A, White

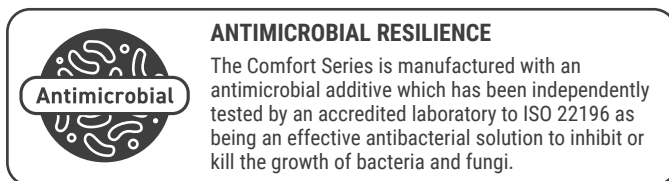

TECHNICAL DATA

PART NUMBER	CSWP3L16WH
DESCRIPTION	Comfort Switch 3 Gang, 2-Way, with red LED "ON" indicator, 16A, White
SUPPLY VOLTAGE	230-240Va.c.
CURRENT RATING	16A
COLOUR	White
MOUNTING CENTRE	84mm
PLATE SIZE	Standard
SWITCH SIZE	32mm x 48.5mm
COMPLIANCE	AS/NZS 3133, ISO 22196, AS 1428.1 - Design for access and mobility

DIMENSIONS

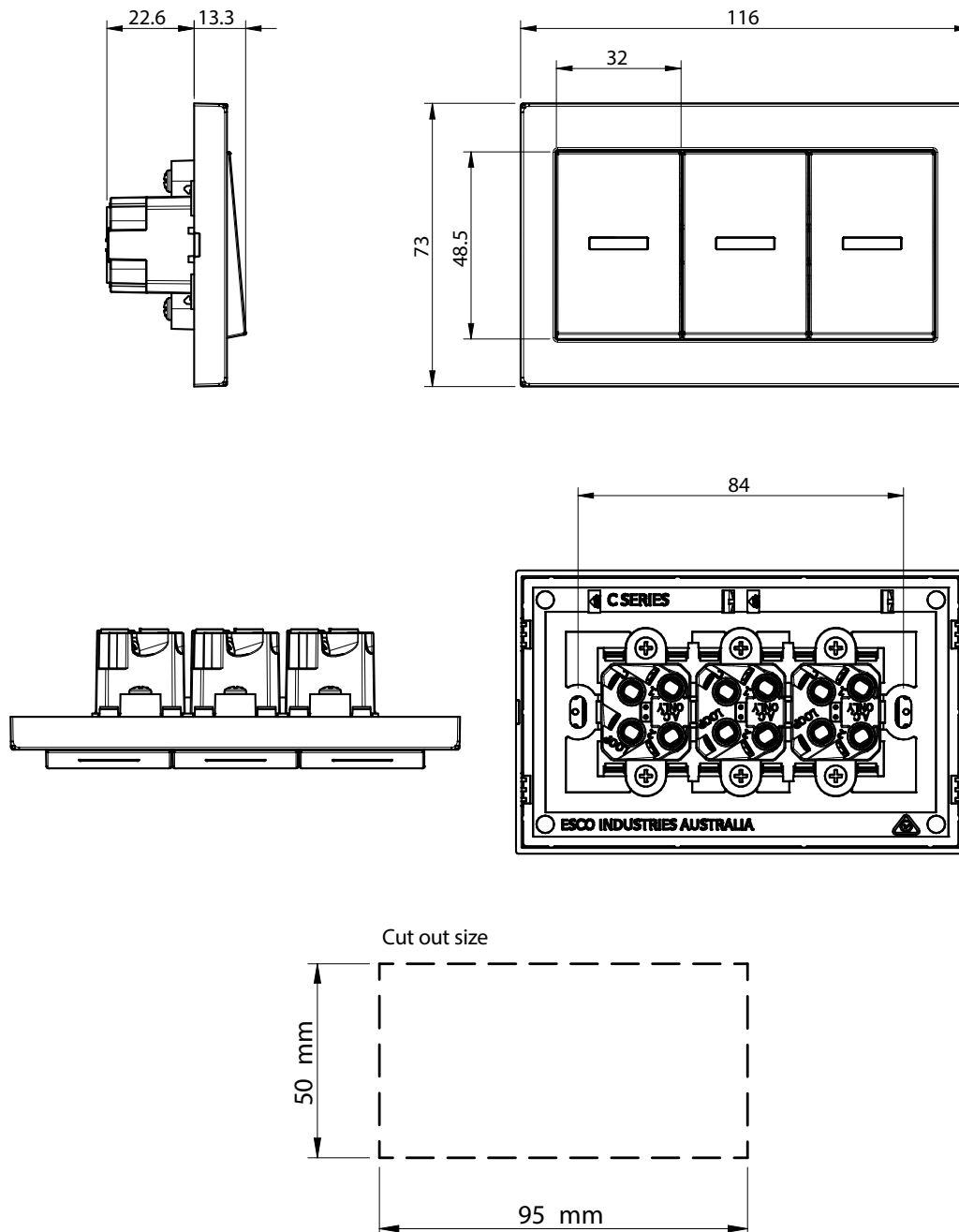

PART NUMBER

CSWPF316WH

MODEL DESCRIPTION

Comfort Switch 3 Gang Full Plate, 2-Way, 16A, White

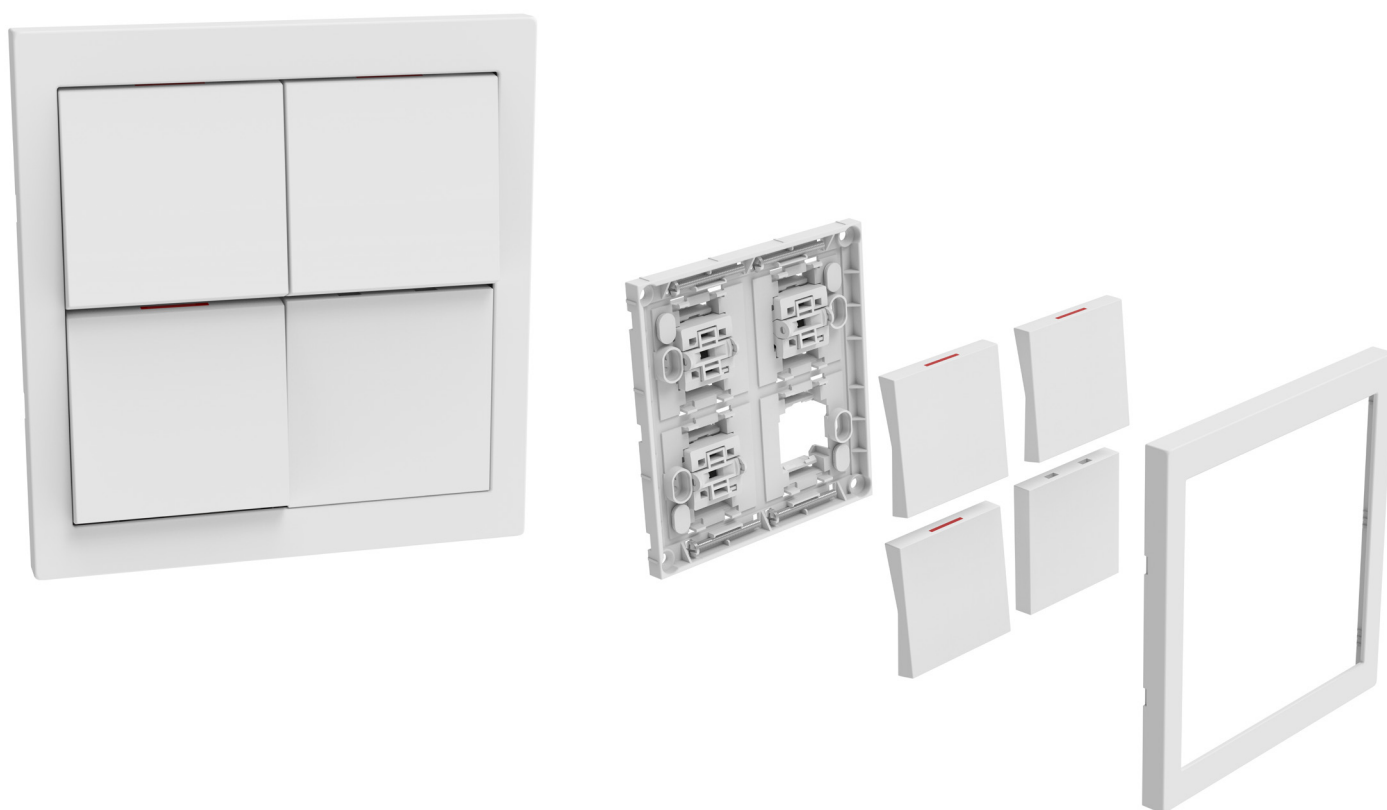
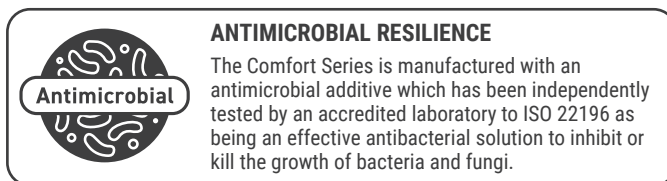

TECHNICAL DATA

PART NUMBER	CSWPF316WH
DESCRIPTION	Comfort Switch 3 Gang Full Plate, 2-Way, 16A, White
SUPPLY VOLTAGE	230-240Va.c.
CURRENT RATING	16A
COLOUR	White
MOUNTING CENTRE	84mm
PLATE SIZE	Large
SWITCH SIZE	48.5mm x 48.5mm
COMPLIANCE	AS/NZS 3133, ISO 22196, AS 1428.1 - Design for access and mobility, Livable Housing Design Guidelines – Switches & Powerpoints (Platinum Level)

DIMENSIONS

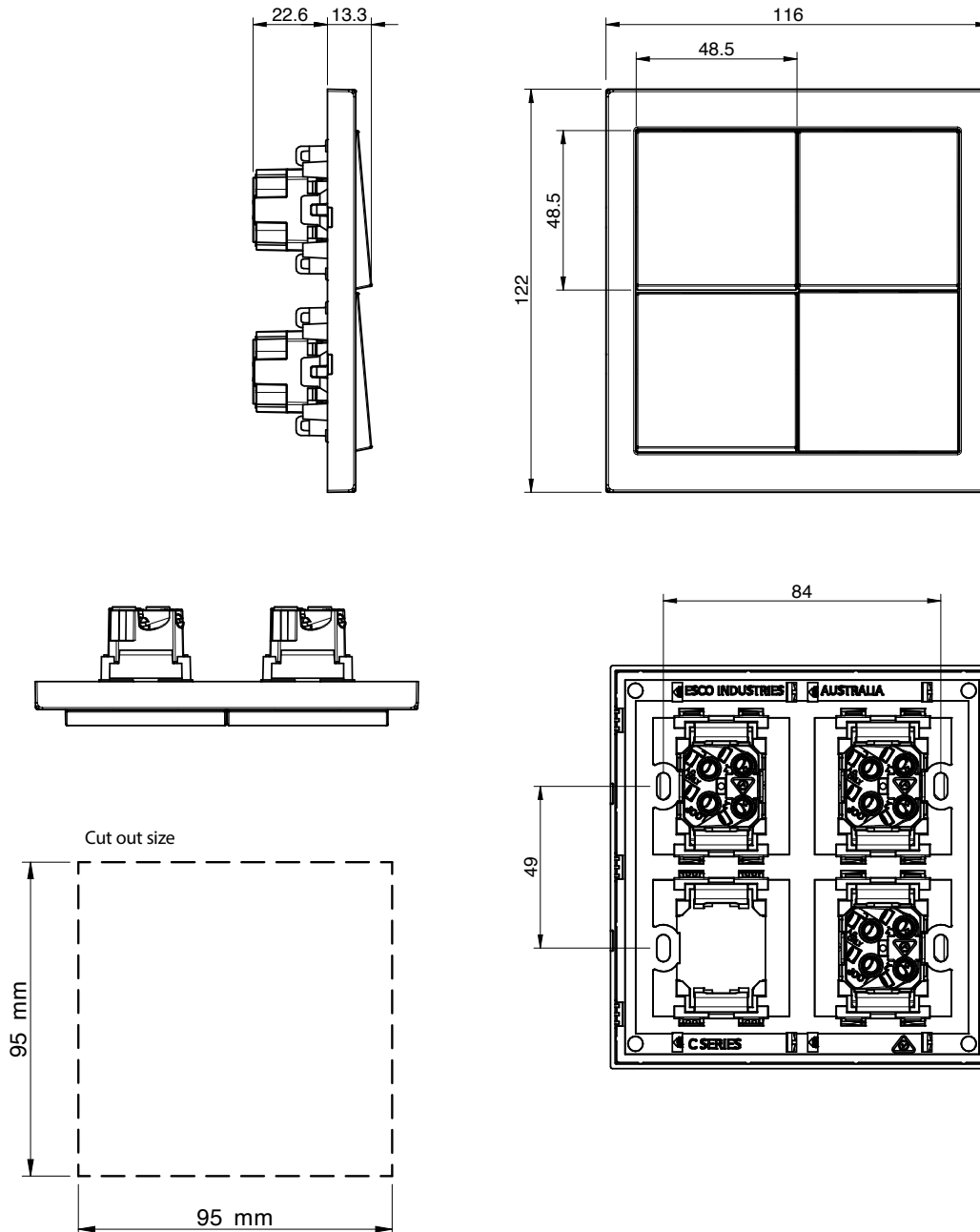

esco
industries

THE ESCO GROUP OF COMPANIES

esco industries MASRAP **MediTek**

modempak

ESCO INDUSTRIES

89 Egerton St (Cnr Fariola & Egerton)
PO Box 6193, Silverwater
NSW 2128 AUSTRALIA

T 1300 879 363 F 1300 879 364
customer.service@escoindustries.com.au
www.escoindustries.com.au

MODEMPAK NZ

Unit 11/273 Neilson St, Onehunga
AUCKLAND 1061 NEW ZEALAND

D +64 9 526 1880 Freecall 0800 663 367
customer.service@modempak.co.nz
www.modempak.co.nz

PART NUMBER

CSWPF3L16WH

MODEL DESCRIPTION

Comfort Switch 3 Gang Full Plate, 2-Way, with red LED 'ON' indicator, 16A, White

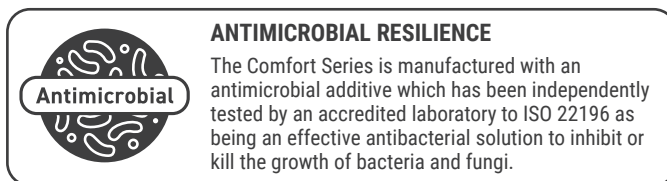

TECHNICAL DATA

PART NUMBER	CSWPF3L16WH
DESCRIPTION	Comfort Switch 3 Gang Full Plate, 2-Way, with red LED 'ON' indicator, 16A, White
SUPPLY VOLTAGE	230-240Va.c.
CURRENT RATING	16A
COLOUR	White
MOUNTING CENTRE	84mm
PLATE SIZE	Large
SWITCH SIZE	48.5mm x 48.5mm
COMPLIANCE	AS/NZS 3133, ISO 22196, AS 1428.1 - Design for access and mobility, Livable Housing Design Guidelines – Switches & Powerpoints (Platinum Level)

DIMENSIONS

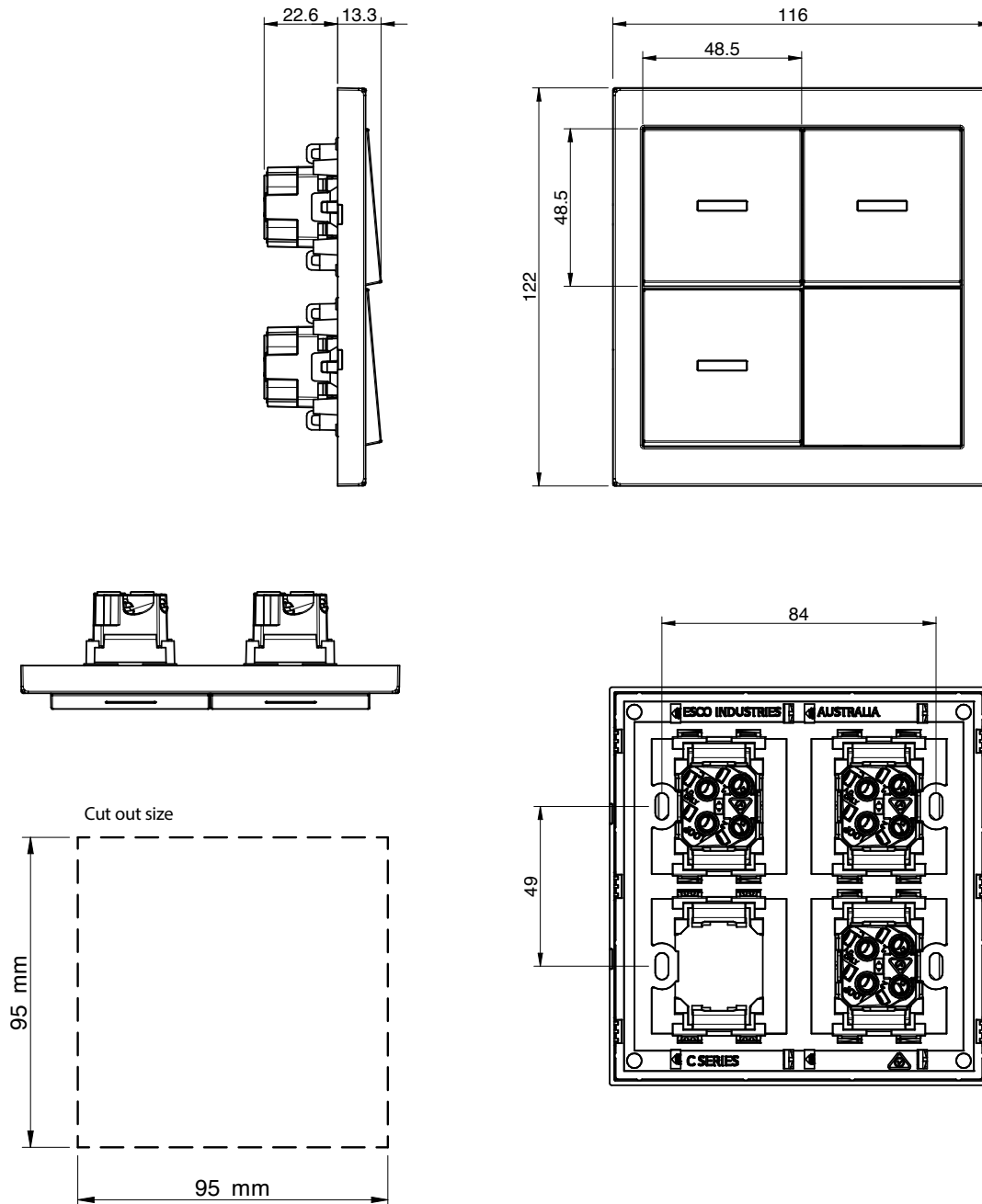

esco
industries

THE ESCO GROUP OF COMPANIES

esco industries MASRAP **MediTek**

modempak

ESCO INDUSTRIES

89 Egerton St (Cnr Fariola & Egerton)
PO Box 6193, Silverwater
NSW 2128 AUSTRALIA

T 1300 879 363 F 1300 879 364
customer.service@escoindustries.com.au
www.escoindustries.com.au

MODEMPAK NZ

Unit 11/273 Neilson St, Onehunga
AUCKLAND 1061 NEW ZEALAND

D +64 9 526 1880 Freecall 0800 663 367
customer.service@modempak.co.nz
www.modempak.co.nz

PART NUMBER

CSWPF416WH

MODEL DESCRIPTION

Comfort Switch 4 Gang Full Plate, 2-Way, 16A, White

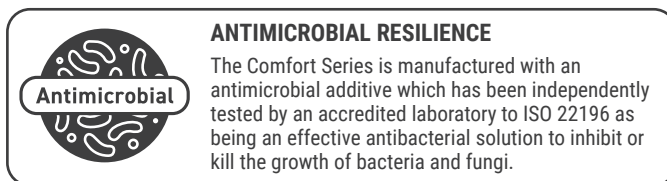

TECHNICAL DATA

PART NUMBER	CSWPF416WH
DESCRIPTION	Comfort Switch 4 Gang Full Plate, 2-Way, 16A, White
SUPPLY VOLTAGE	230-240Va.c.
CURRENT RATING	16A
COLOUR	White
MOUNTING CENTRE	84mm
PLATE SIZE	Large
SWITCH SIZE	48.5mm x 48.5mm
COMPLIANCE	AS/NZS 3133, ISO 22196, AS 1428.1 - Design for access and mobility, Livable Housing Design Guidelines – Switches & Powerpoints (Platinum Level)

DIMENSIONS

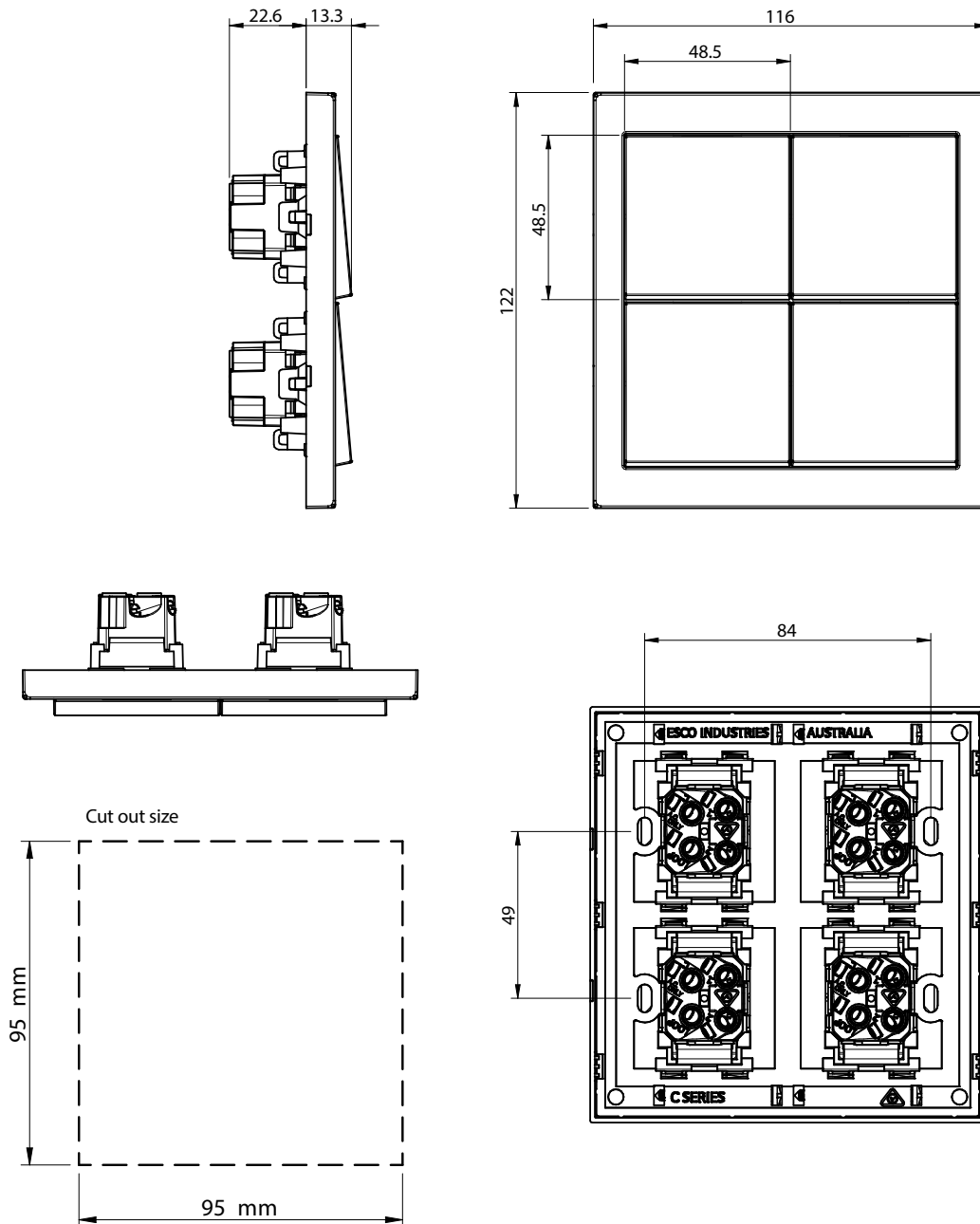

esco
industries

THE ESCO GROUP OF COMPANIES

esco industries MASRAP **MediTek**

modempak

ESCO INDUSTRIES

89 Egerton St (Cnr Fariola & Egerton)
PO Box 6193, Silverwater
NSW 2128 AUSTRALIA

T 1300 879 363 F 1300 879 364
customer.service@escoindustries.com.au
www.escoindustries.com.au

MODEMPAK NZ

Unit 11/273 Neilson St, Onehunga
AUCKLAND 1061 NEW ZEALAND

D +64 9 526 1880 Freecall 0800 663 367
customer.service@modempak.co.nz
www.modempak.co.nz

PART NUMBER

CSWPF4L16WH

MODEL DESCRIPTION

Comfort Switch 4 Gang Full Plate, 2-Way, with red LED 'ON' indicator, 16A, White

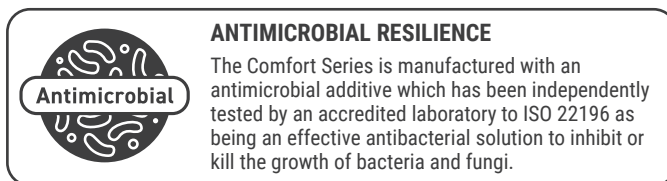

TECHNICAL DATA

PART NUMBER	CSWPF4L16WH
DESCRIPTION	Comfort Switch 4 Gang Full Plate, 2-Way, with red LED 'ON' indicator, 16A, White
SUPPLY VOLTAGE	230-240Va.c.
CURRENT RATING	16A
COLOUR	White
MOUNTING CENTRE	84mm
PLATE SIZE	Large
SWITCH SIZE	48.5mm x 48.5mm
COMPLIANCE	AS/NZS 3133, ISO 22196, AS 1428.1 - Design for access and mobility, Livable Housing Design Guidelines – Switches & Powerpoints (Platinum Level)

DIMENSIONS

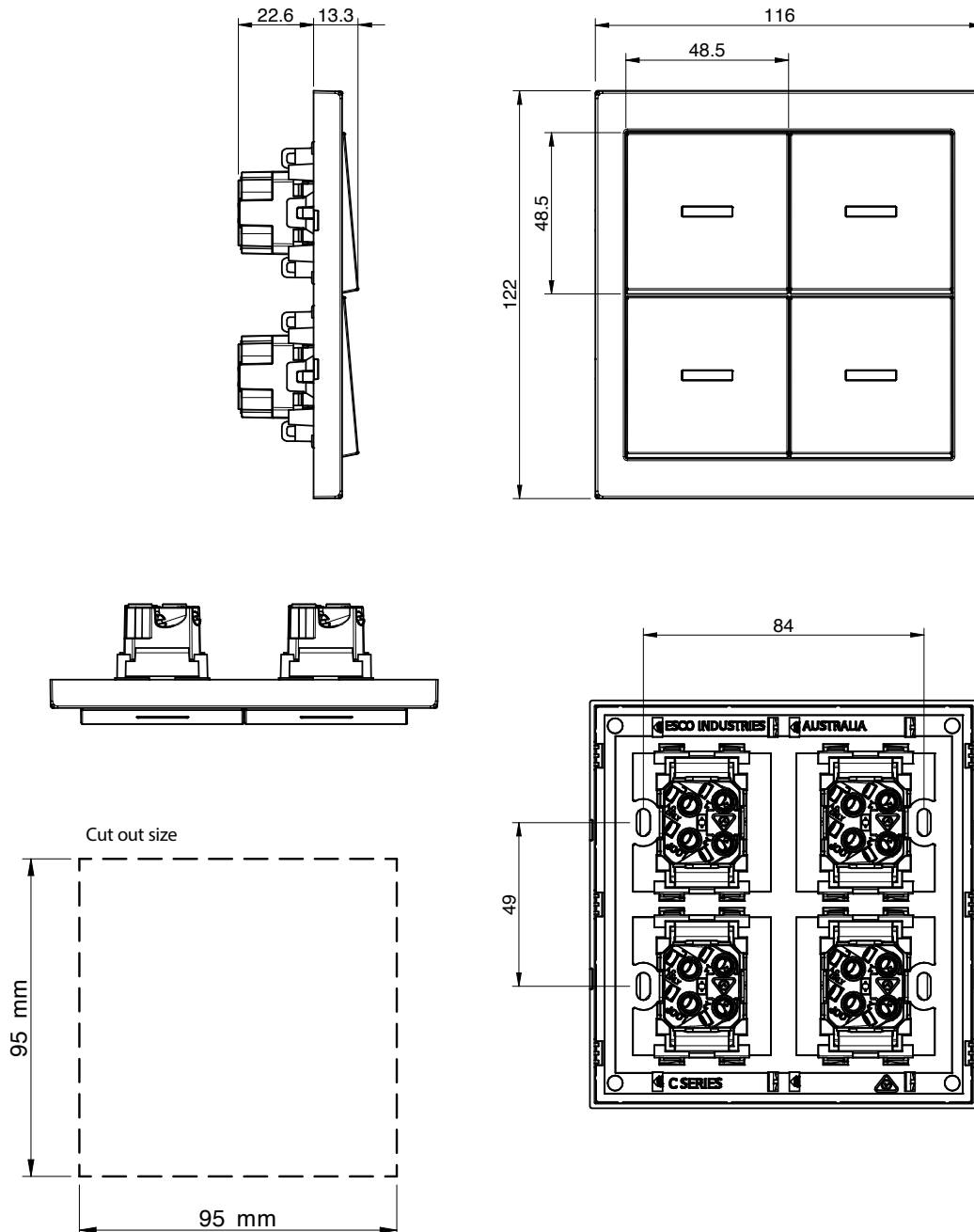

ESCO INDUSTRIES
89 Egerton St (Cnr Fariola & Egerton)
PO Box 6193, Silverwater
NSW 2128 AUSTRALIA

T 1300 879 363 F 1300 879 364
customer.service@escoindustries.com.au
www.escoindustries.com.au

THE ESCO GROUP OF COMPANIES



modempak

MODEMPAK NZ
Unit 11/273 Neilson St, Onehunga
AUCKLAND 1061 NEW ZEALAND

D +64 9 526 1880 Freecall 0800 663 367
customer.service@modempak.co.nz
www.modempak.co.nz

PART NUMBER

CSW116WH

MODEL DESCRIPTION

Comfort Switch Mech 1 Gang, 2-Way, 16A, White

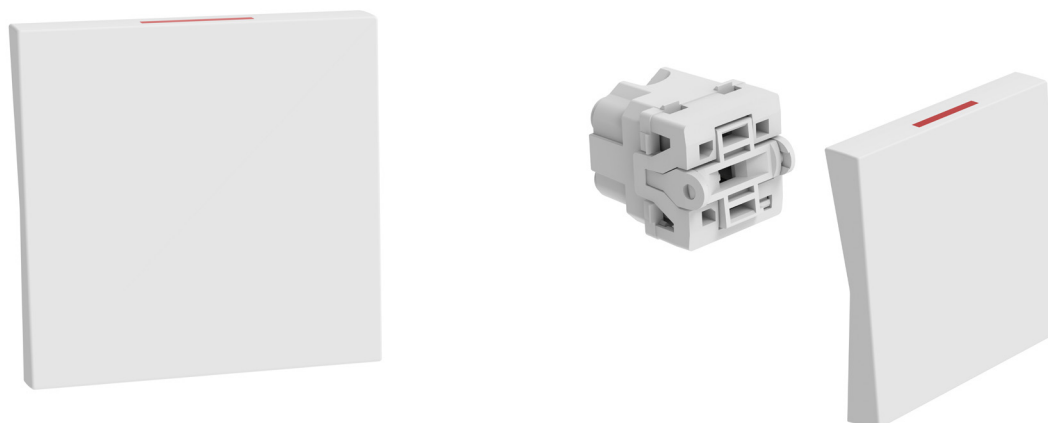
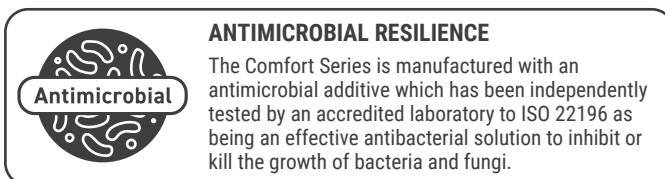

TECHNICAL DATA

PART NUMBER	CSW116WH
DESCRIPTION	Comfort Switch Mech 1 Gang, 2-Way, 16A, White
SUPPLY VOLTAGE	230-240Va.c.
CURRENT RATING	16A
COLOUR	White
MOUNTING CENTRE	N/A
PLATE SIZE	N/A
SWITCH SIZE	48.5mm x 48.5mm
COMPLIANCE	AS/NZS 3133, ISO 22196, AS 1428.1 - Design for access and mobility, Livable Housing Design Guidelines – Switches & Powerpoints (Platinum Level)

DIMENSIONS

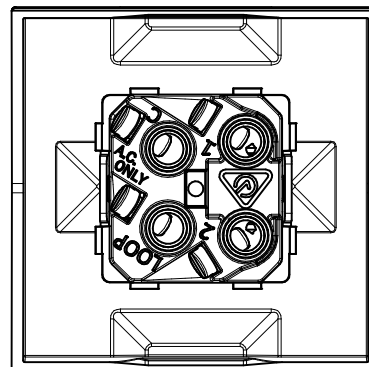
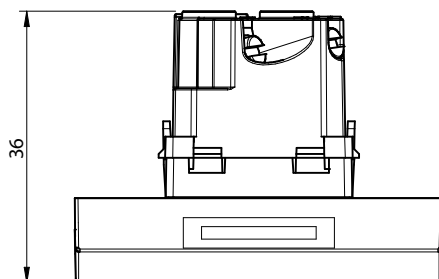
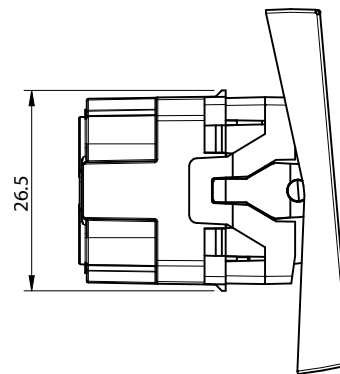
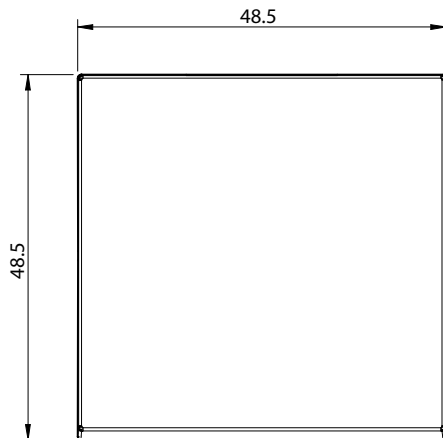

esco
industries

THE ESCO GROUP OF COMPANIES

esco industries MASRAP **MediTek**

modempak

ESCO INDUSTRIES

89 Egerton St (Cnr Fariola & Egerton)
PO Box 6193, Silverwater
NSW 2128 AUSTRALIA

T 1300 879 363 **F** 1300 879 364
customer.service@escoindustries.com.au
www.escoindustries.com.au

MODEMPAK NZ

Unit 11/273 Neilson St, Onehunga
AUCKLAND 1061 NEW ZEALAND

D +64 9 526 1880 **Freecall** 0800 663 367
customer.service@modempak.co.nz
www.modempak.co.nz

PART NUMBER

CSW1L16WH

MODEL DESCRIPTION

Comfort Switch Mech 1 Gang, 2-Way, with red LED 'ON' indicator, 16A, White



ANTIMICROBIAL RESILIENCE

The Comfort Series is manufactured with an antimicrobial additive which has been independently tested by an accredited laboratory to ISO 22196 as being an effective antibacterial solution to inhibit or kill the growth of bacteria and fungi.

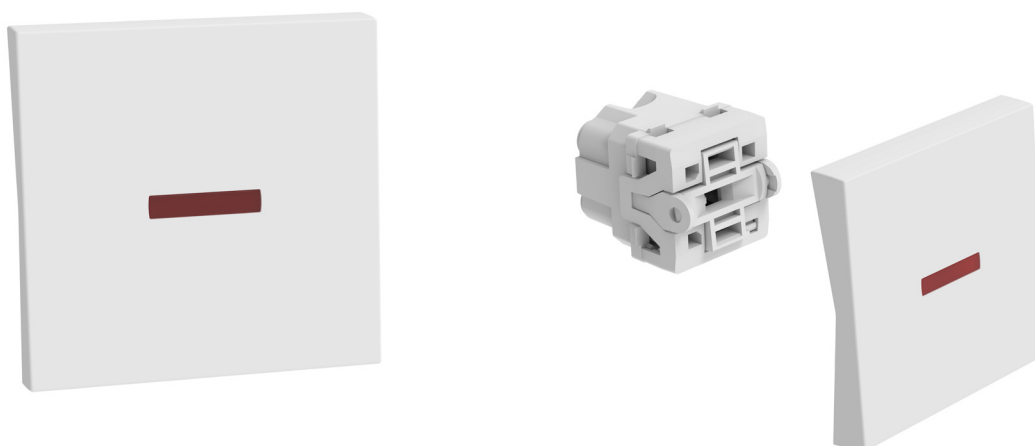

TECHNICAL DATA

PART NUMBER	CSW1L16WH
DESCRIPTION	Comfort Switch Mech 1 Gang, 2-Way, with red LED 'ON' indicator, 16A, White
SUPPLY VOLTAGE	230-240Va.c.
CURRENT RATING	16A
COLOUR	White
MOUNTING CENTRE	N/A
PLATE SIZE	N/A
SWITCH SIZE	48.5mm x 48.5mm
COMPLIANCE	AS/NZS 3133, ISO 22196, AS 1428.1 - Design for access and mobility, Livable Housing Design Guidelines – Switches & Powerpoints (Platinum Level)

DIMENSIONS

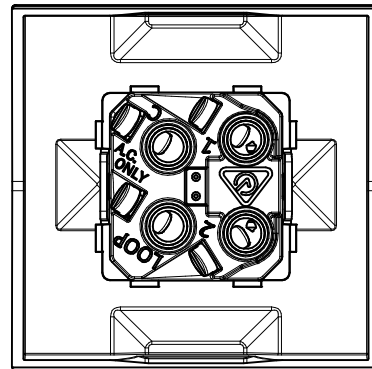
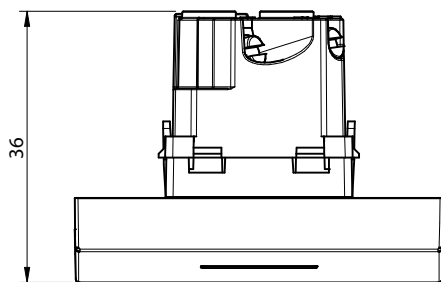
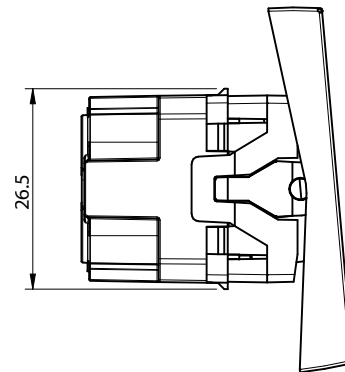
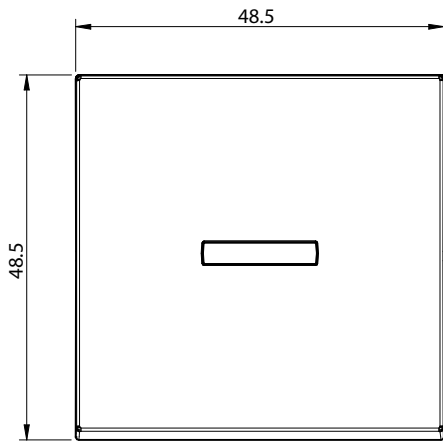

esco
industries

THE ESCO GROUP OF COMPANIES

esco industries MASRAP **MediTek**

modempak

ESCO INDUSTRIES

89 Egerton St (Cnr Fariola & Egerton)
PO Box 6193, Silverwater
NSW 2128 AUSTRALIA

T 1300 879 363 **F** 1300 879 364
customer.service@escoindustries.com.au
www.escoindustries.com.au

MODEMPAK NZ

Unit 11/273 Neilson St, Onehunga
AUCKLAND 1061 NEW ZEALAND

D +64 9 526 1880 **Freecall** 0800 663 367
customer.service@modempak.co.nz
www.modempak.co.nz

PART NUMBER

CSW1DP16WH

MODEL DESCRIPTION

Comfort Switch Mech 1 Gang, 2-Way, Double Pole, 16A, White

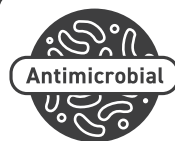

ANTIMICROBIAL RESILIENCE

The Comfort Series is manufactured with an antimicrobial additive which has been independently tested by an accredited laboratory to ISO 22196 as being an effective antibacterial solution to inhibit or kill the growth of bacteria and fungi.

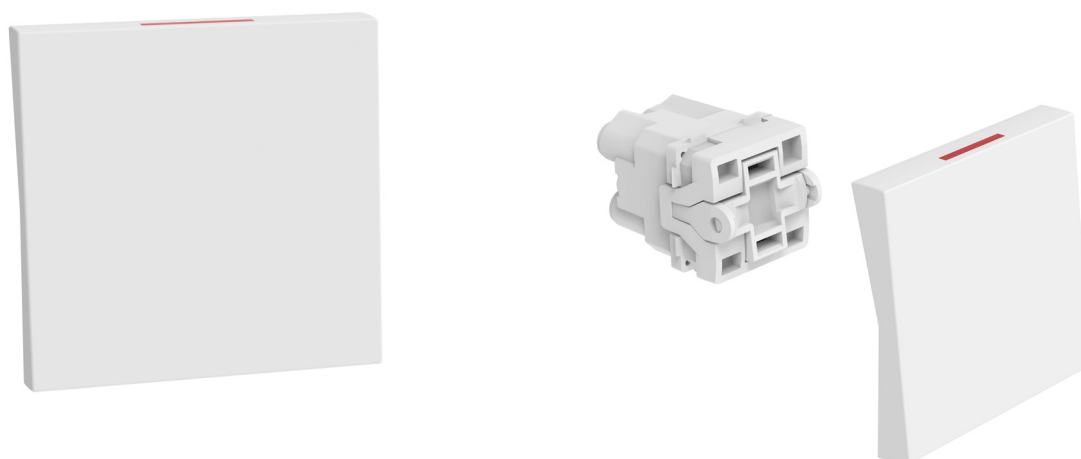

TECHNICAL DATA

PART NUMBER	CSW1DP16WH
DESCRIPTION	Comfort Switch Mech 1 Gang, 2-Way, Double Pole, 16A, White
SUPPLY VOLTAGE	230-240Va.c.
CURRENT RATING	16A
COLOUR	White
MOUNTING CENTRE	N/A
PLATE SIZE	N/A
SWITCH SIZE	48.5mm x 48.5mm
COMPLIANCE	AS/NZS 3133, ISO 22196, AS 1428.1 - Design for access and mobility, Livable Housing Design Guidelines – Switches & Powerpoints (Platinum Level)

DIMENSIONS

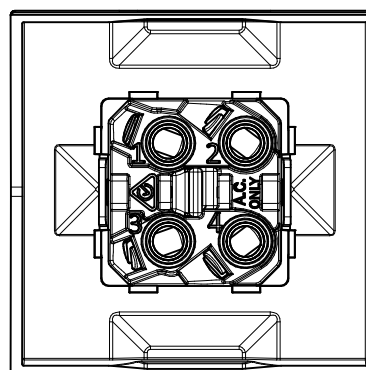
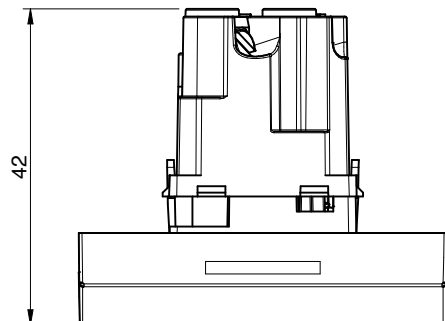
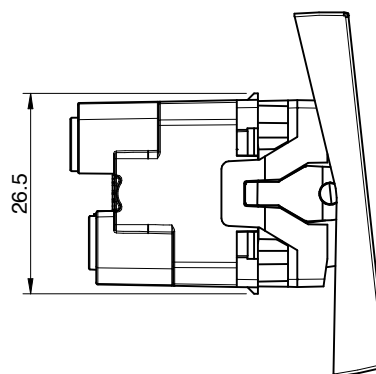
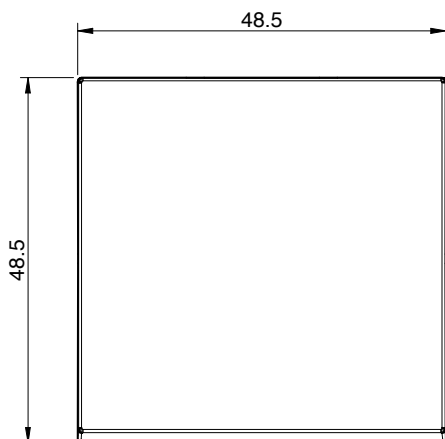

esco
industries

THE ESCO GROUP OF COMPANIES

esco industries MASRAP **MediTek**

modempak

ESCO INDUSTRIES

89 Egerton St (Cnr Fariola & Egerton)
PO Box 6193, Silverwater
NSW 2128 AUSTRALIA

T 1300 879 363 **F** 1300 879 364
customer.service@escoindustries.com.au
www.escoindustries.com.au

MODEMPAK NZ

Unit 11/273 Neilson St, Onehunga
AUCKLAND 1061 NEW ZEALAND

D +64 9 526 1880 **Freecall** 0800 663 367
customer.service@modempak.co.nz
www.modempak.co.nz

PART NUMBER

CSW1INT16WH

MODEL DESCRIPTION

Comfort Switch Mech 1 Gang, Intermediate, 16A, White

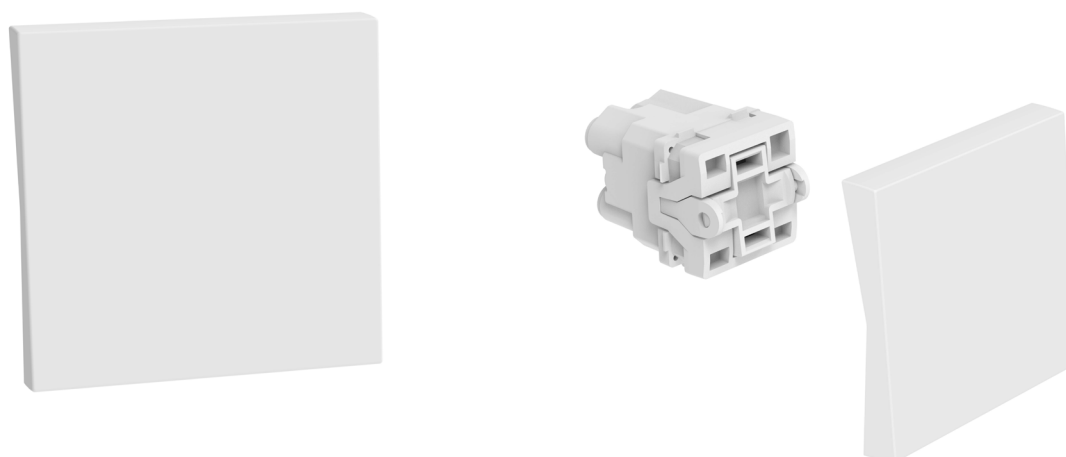
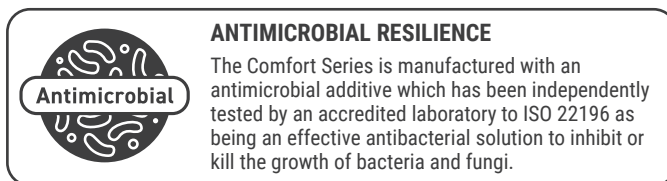

TECHNICAL DATA

PART NUMBER	CSW1INT16WH
DESCRIPTION	Comfort Switch Mech 1 Gang, Intermediate, 16A, White
SUPPLY VOLTAGE	230-240Va.c.
CURRENT RATING	16A
COLOUR	White
MOUNTING CENTRE	N/A
PLATE SIZE	N/A
SWITCH SIZE	48.5mm x 48.5mm
COMPLIANCE	AS/NZS 3133, ISO 22196, AS 1428.1 - Design for access and mobility, Livable Housing Design Guidelines – Switches & Powerpoints (Platinum Level)

DIMENSIONS

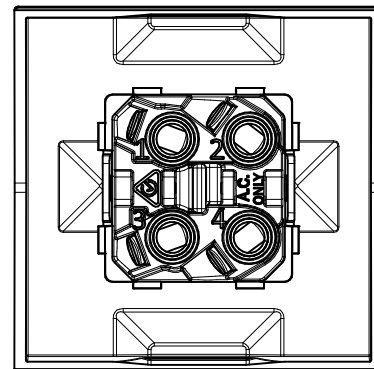
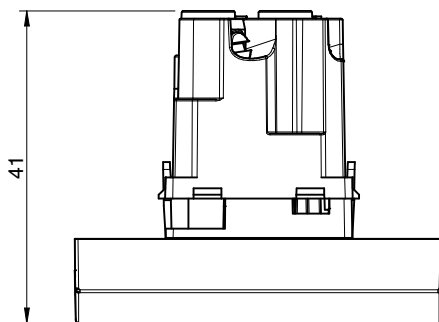
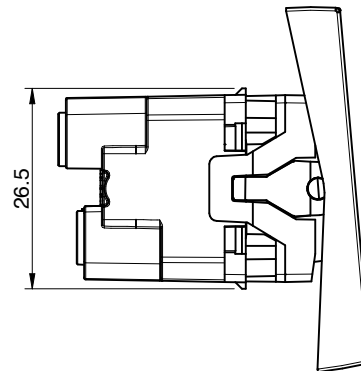
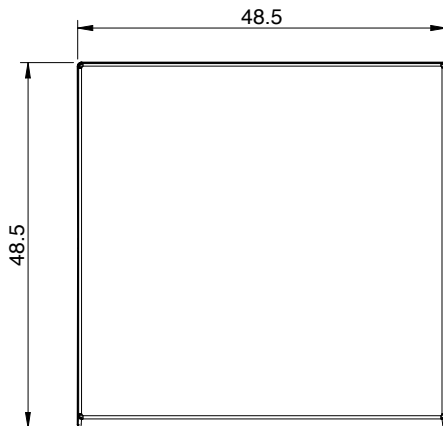

PART NUMBER

CSWPBWH

MODEL DESCRIPTION

Comfort Switch Mech 1 Gang, Momentary Push Button marked PRESS,16A, White

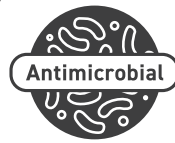

ANTIMICROBIAL RESILIENCE

The Comfort Series is manufactured with an antimicrobial additive which has been independently tested by an accredited laboratory to ISO 22196 as being an effective antibacterial solution to inhibit or kill the growth of bacteria and fungi.



TECHNICAL DATA

PART NUMBER	CSWPBWH
DESCRIPTION	Comfort Switch Mech 1 Gang, Momentary Push Button marked PRESS,10A, White
SUPPLY VOLTAGE	230-240Va.c.
CURRENT RATING	16A
COLOUR	White
MOUNTING CENTRE	N/A
PLATE SIZE	N/A
SWITCH SIZE	48.5mm x 48.5mm
COMPLIANCE	AS/NZS 3133, ISO 22196, AS 1428.1 - Design for access and mobility, Livable Housing Design Guidelines – Switches & Powerpoints (Platinum Level)

DIMENSIONS

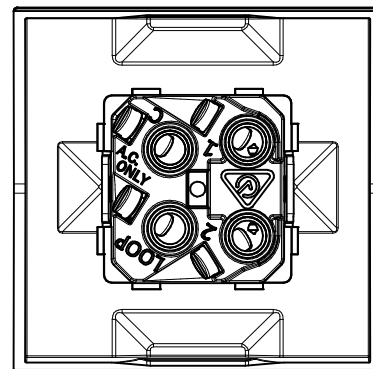
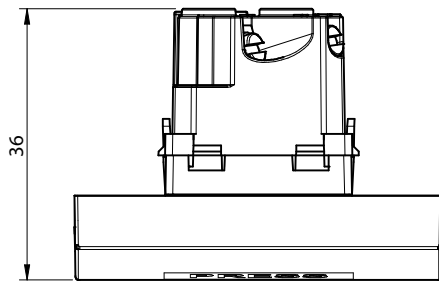
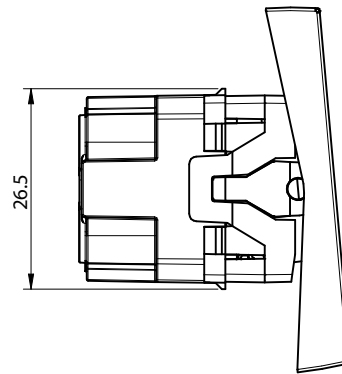
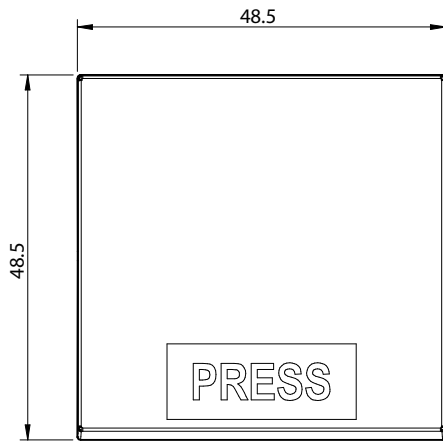

esco
industries

THE ESCO GROUP OF COMPANIES

esco industries MASRAP MediTek

modempak

ESCO INDUSTRIES

89 Egerton St (Cnr Fariola & Egerton)
PO Box 6193, Silverwater
NSW 2128 AUSTRALIA

T 1300 879 363 **F** 1300 879 364
customer.service@escoindustries.com.au
www.escoindustries.com.au

MODEMPAK NZ

Unit 11/273 Neilson St, Onehunga
AUCKLAND 1061 NEW ZEALAND

D +64 9 526 1880 **Freecall** 0800 663 367
customer.service@modempak.co.nz
www.modempak.co.nz

PART NUMBER

CBMWH

MODEL DESCRIPTION

Blank Mechanism, White

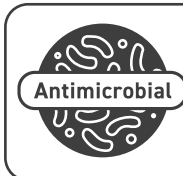

ANTIMICROBIAL RESILIENCE

The Comfort Series is manufactured with an antimicrobial additive which has been independently tested by an accredited laboratory to ISO 22196 as being an effective antibacterial solution to inhibit or kill the growth of bacteria and fungi.



TECHNICAL DATA

PART NUMBER	CBMWH
DESCRIPTION	Blank Mechanism, White
SUPPLY VOLTAGE	N/A
CURRENT RATING	N/A
COLOUR	White
MOUNTING CENTRE	N/A
PLATE SIZE	N/A
COMPLIANCE	ISO 22196

DIMENSIONS

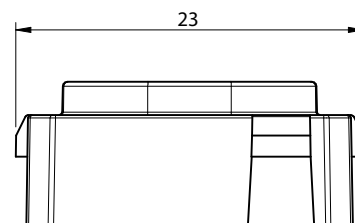
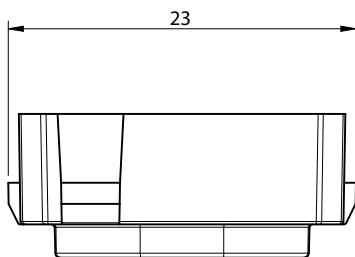
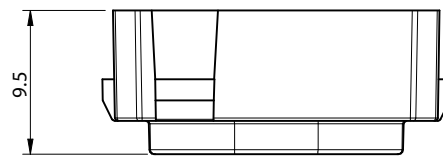
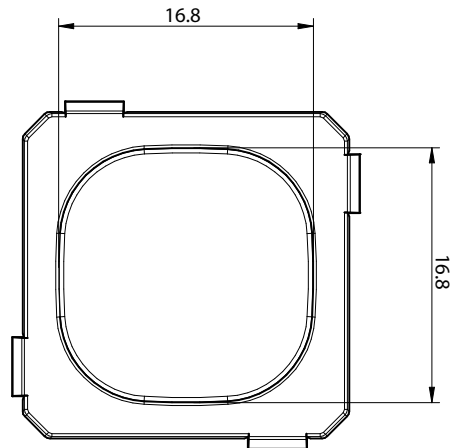

esco
industries

THE ESCO GROUP OF COMPANIES

esco industries MASRAP **MediTek**

modempak

ESCO INDUSTRIES

89 Egerton St (Cnr Fariola & Egerton)
PO Box 6193, Silverwater
NSW 2128 AUSTRALIA

MODEMPAK NZ

Unit 11/273 Neilson St, Onehunga
AUCKLAND 1061 NEW ZEALAND

T 1300 879 363 **F** 1300 879 364

customer.service@escoindustries.com.au
www.escoindustries.com.au

D +64 9 526 1880 **Freecall** 0800 663 367

customer.service@modempak.co.nz
www.modempak.co.nz