

WD Series Galvanized Steel Service Duct & Fittings

Mechanical Protection for segregation of Services and Cable Reticulation

ESCO can provide a duct suitable for almost any need or application with its range of WD Series Cableway Service Ducting to provide the ultimate in protection from Accidental Damage Ingress or simply physical barriers or voltage and services segregation

Applications Include - security, data & telecommunications, audio visual or light & power cable protection for integrity plus reticulation and separation of services or to distribute specific cables for special needs

Available in either Clip-On Lid or Screw Fix Cover Options as well as in specialised materials like Stainless Steel or Powder Coated Finishes (upon request)

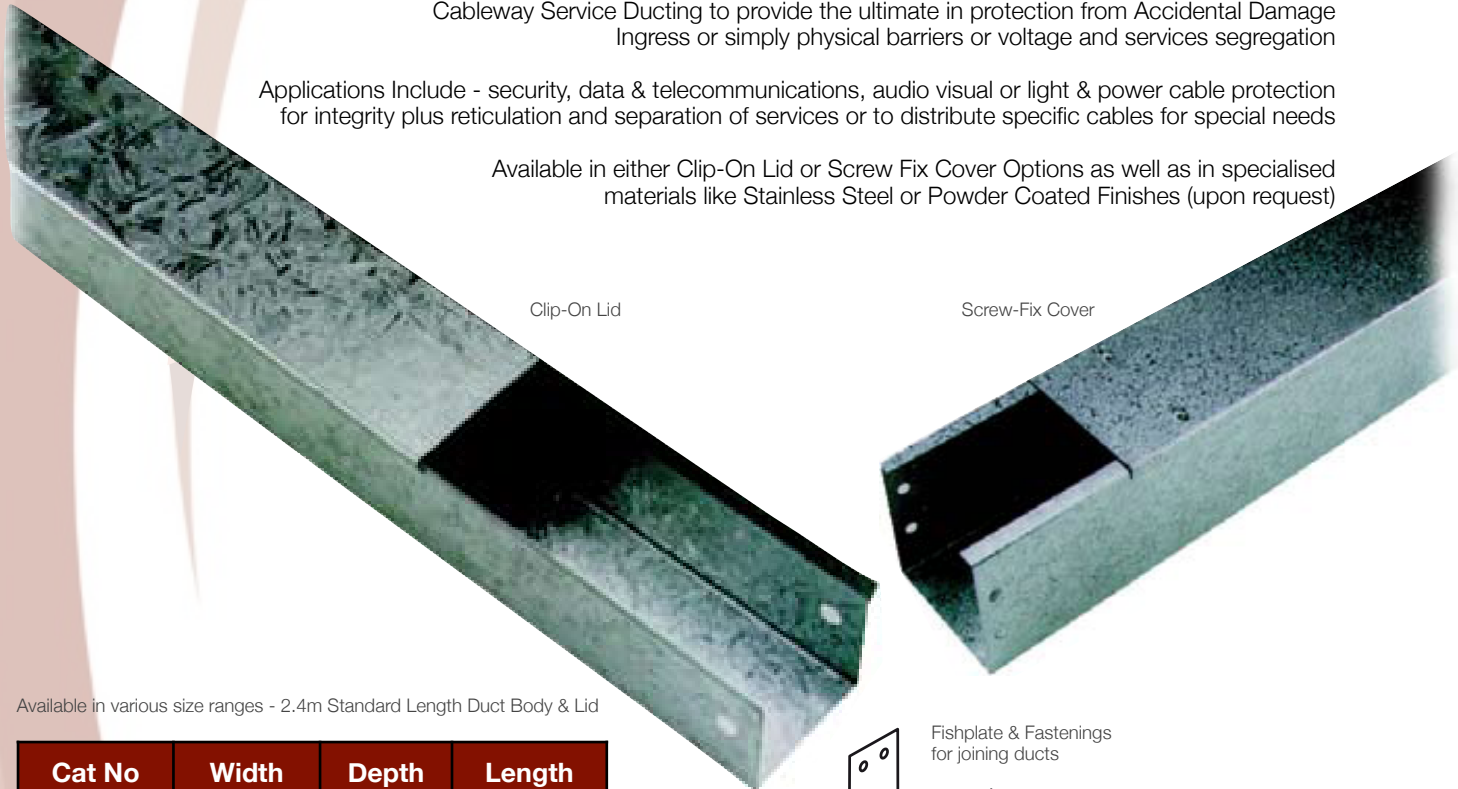

Clip-On Lid

Screw-Fix Cover

Available in various size ranges - 2.4m Standard Length Duct Body & Lid

Cat No	Width	Depth	Length
WD10	38mm	38mm	2400mm
WD22	50mm	50mm	2400mm
WD32	75mm	50mm	2400mm
WD33	75mm	75mm	2400mm
WD43	100mm	75mm	2400mm
WD44	100mm	100mm	2400mm
WD63	150mm	75mm	2400mm
WD64	150mm	100mm	2400mm
WD93	225mm	75mm	2400mm
WD123	300mm	75mm	2400mm

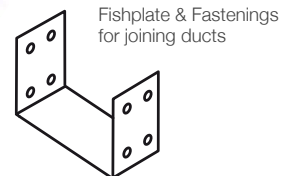

Fishplate & Fastenings
for joining ducts

ESCO provide cable protection for all applications including Light & Power, A/V, Security, Data & Comms Cabling plus Fibre Optics and other special needs

Cable Carrying Capability & Security
 Depending on Integrity with the ability to
 protect with ease and features.

ESCO is a recognised market leader in the design and manufacture of Cable Management and Cable Reticulation products for use in Information Technology, Security Audio Visual and Electrical Distribution industries.

Be it a safe place to house, mount, protect or distribute your most valuable assets including your Cable Management and Connections, Audio Visual Equipment, Telecommunications, Data or Server, Information Technology and much more...



Warehouse Installation
 Cable Ducting along Ceiling Beams
 Service Columns up Risers Poles

Mounting options and accessories
 to suit all WD series duct sizes.

simply add the part number designator for each accessory to the size of duct (on the end) for the correct ordering code - eg WD63BE (BlankEnd)

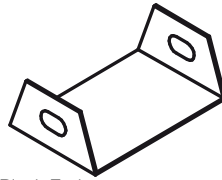
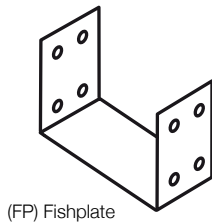
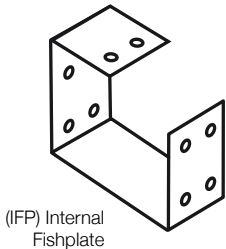

Department of Energy Certification No - 6939
 Manufactured in Australia by ESCO Industries

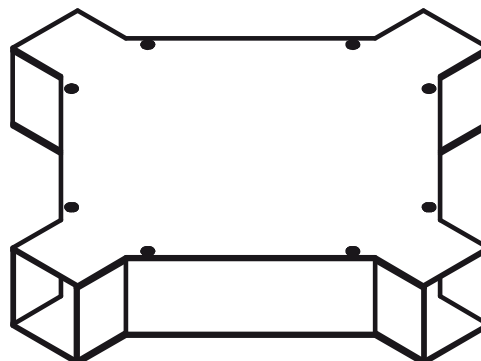
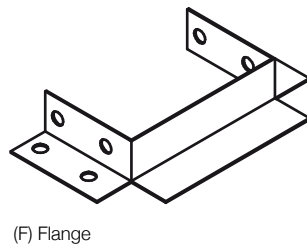
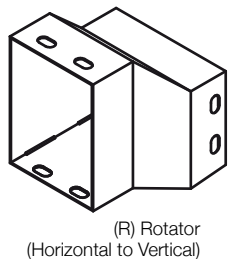
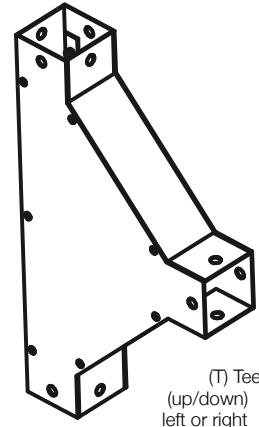
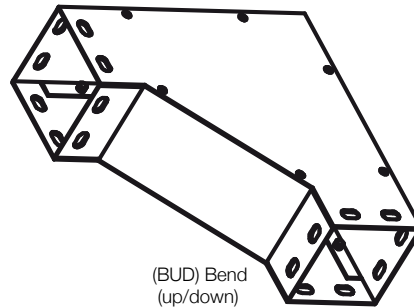
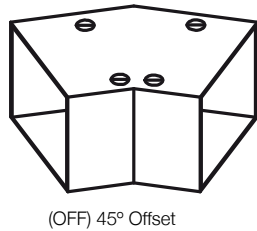
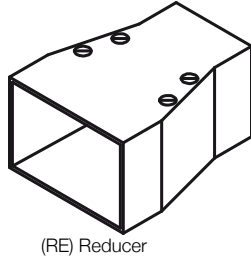

**WD DUCT
 CABLEWAY**

Contact your local ESCO representative to discuss your project requirements directly for further information or samples. Separate product catalogues for each range available upon request or via our website - please ask for any specific information



HEAD OFFICE
 Unit 37, Slough Business Park
 Holker Street, Silverwater
 NSW 2128, Australia
 E: customer.service@escoindustries.com.au
www.escoindustries.com.au

T: 1300 879 363
F: 1300 879 364