

PART NUMBER

CSW116WH

MODEL DESCRIPTION

Comfort Switch Mech 1 Gang, 2-Way, 16A, White

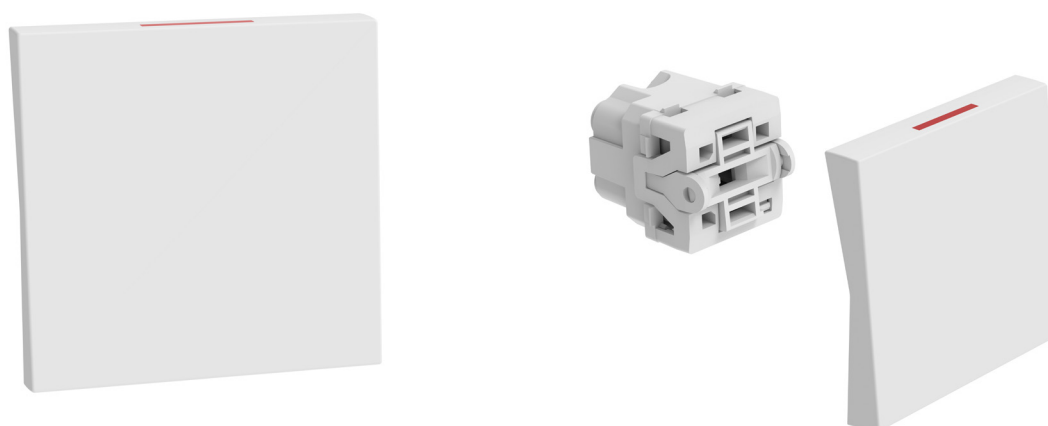
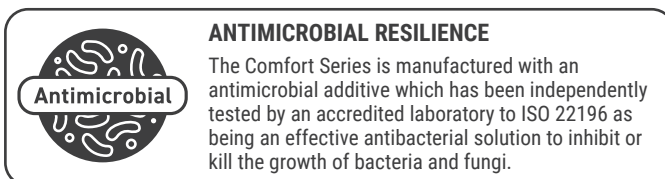

TECHNICAL DATA

PART NUMBER	CSW116WH
DESCRIPTION	Comfort Switch Mech 1 Gang, 2-Way, 16A, White
SUPPLY VOLTAGE	230-240Va.c.
CURRENT RATING	16A
COLOUR	White
MOUNTING CENTRE	N/A
PLATE SIZE	N/A
SWITCH SIZE	48.5mm x 48.5mm
COMPLIANCE	AS/NZS 3133, ISO 22196, AS 1428.1 - Design for access and mobility, Livable Housing Design Guidelines – Switches & Powerpoints (Platinum Level)

DIMENSIONS

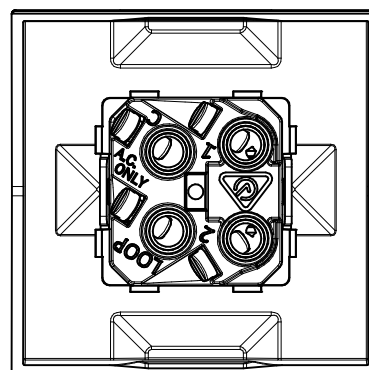
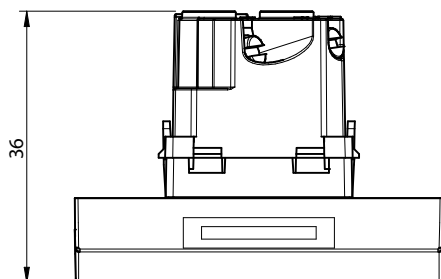
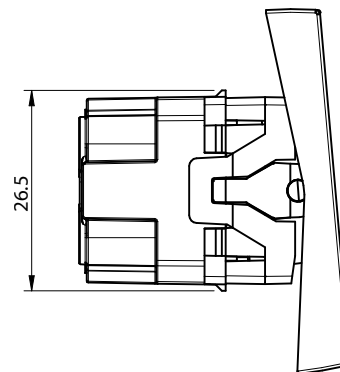
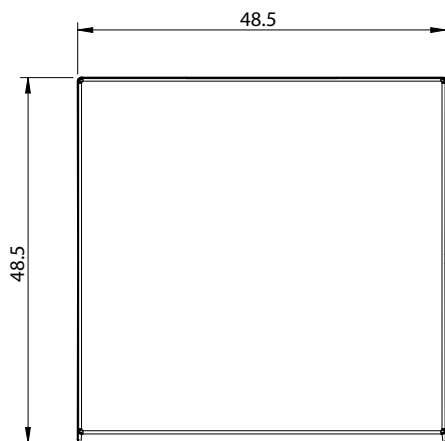

esco
industries

THE ESCO GROUP OF COMPANIES

esco industries MASRAP MediTek

modempak

ESCO INDUSTRIES

89 Egerton St (Cnr Fariola & Egerton)
PO Box 6193, Silverwater
NSW 2128 AUSTRALIA

T 1300 879 363 F 1300 879 364

customer.service@escoindustries.com.au
www.escoindustries.com.au

MODEMPAK NZ

Unit 11/273 Neilson St, Onehunga
AUCKLAND 1061 NEW ZEALAND

D +64 9 526 1880 Freecall 0800 663 367

customer.service@modempak.co.nz
www.modempak.co.nz

PART NUMBER

CSW1L16WH

MODEL DESCRIPTION

Comfort Switch Mech 1 Gang, 2-Way, with red LED 'ON' indicator, 16A, White



ANTIMICROBIAL RESILIENCE

The Comfort Series is manufactured with an antimicrobial additive which has been independently tested by an accredited laboratory to ISO 22196 as being an effective antibacterial solution to inhibit or kill the growth of bacteria and fungi.

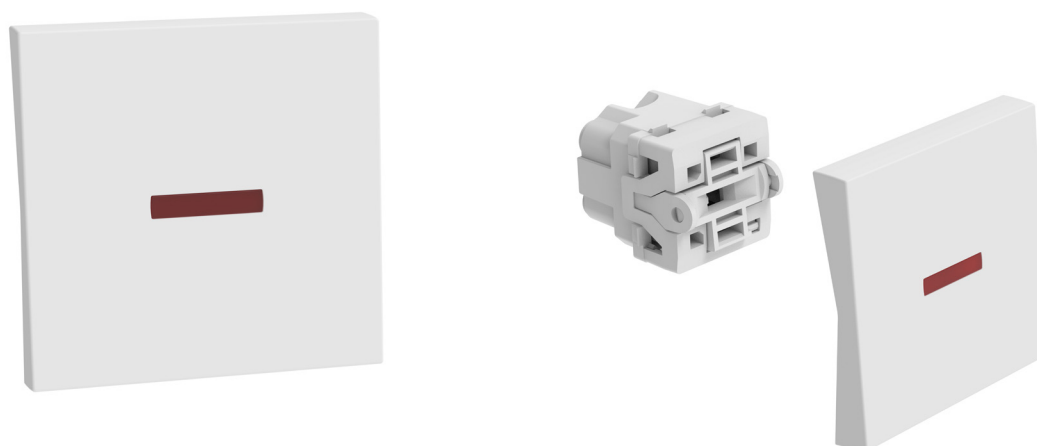

TECHNICAL DATA

PART NUMBER	CSW1L16WH
DESCRIPTION	Comfort Switch Mech 1 Gang, 2-Way, with red LED 'ON' indicator, 16A, White
SUPPLY VOLTAGE	230-240Va.c.
CURRENT RATING	16A
COLOUR	White
MOUNTING CENTRE	N/A
PLATE SIZE	N/A
SWITCH SIZE	48.5mm x 48.5mm
COMPLIANCE	AS/NZS 3133, ISO 22196, AS 1428.1 - Design for access and mobility, Livable Housing Design Guidelines – Switches & Powerpoints (Platinum Level)

DIMENSIONS

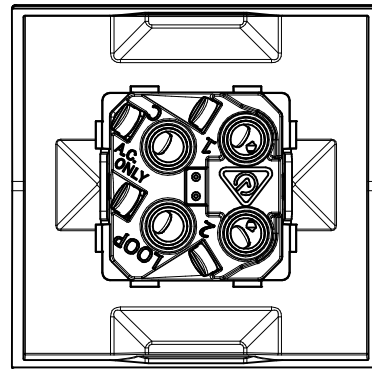
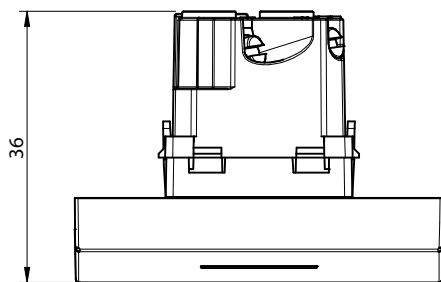
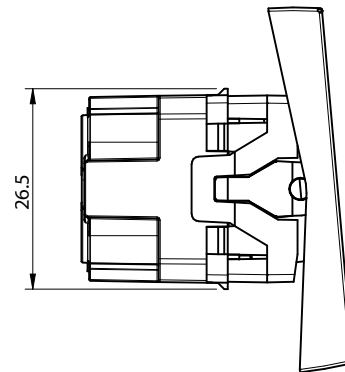
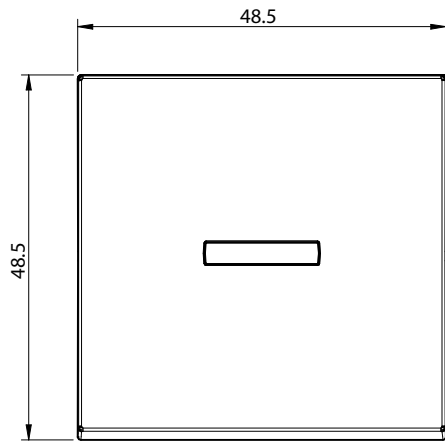

esco
industries

THE ESCO GROUP OF COMPANIES

esco industries MASRAP **MediTek**

modempak

ESCO INDUSTRIES

89 Egerton St (Cnr Fariola & Egerton)
PO Box 6193, Silverwater
NSW 2128 AUSTRALIA

T 1300 879 363 F 1300 879 364

customer.service@escoindustries.com.au
www.escoindustries.com.au

MODEMPAK NZ

Unit 11/273 Neilson St, Onehunga
AUCKLAND 1061 NEW ZEALAND

D +64 9 526 1880 **Freecall** 0800 663 367

customer.service@modempak.co.nz
www.modempak.co.nz

PART NUMBER

CSW1DP16WH

MODEL DESCRIPTION

Comfort Switch Mech 1 Gang, 2-Way, Double Pole, 16A, White

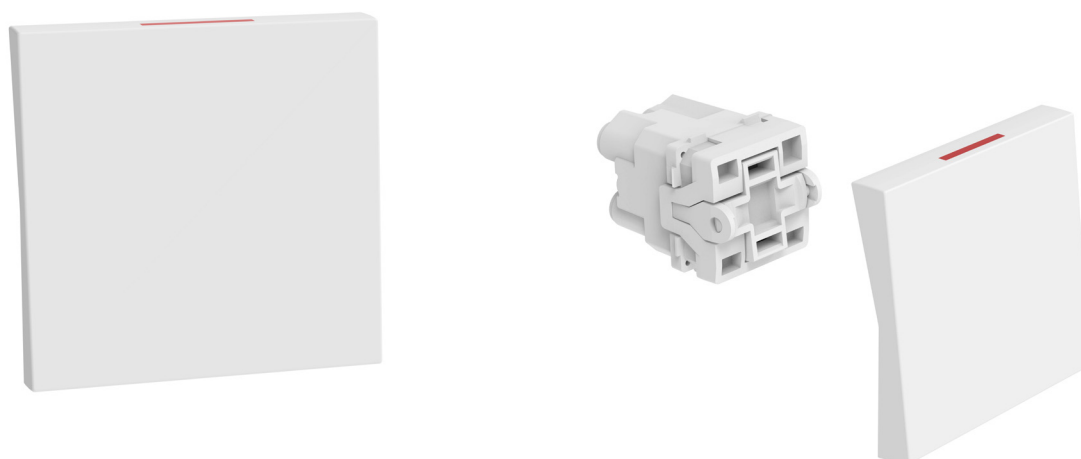
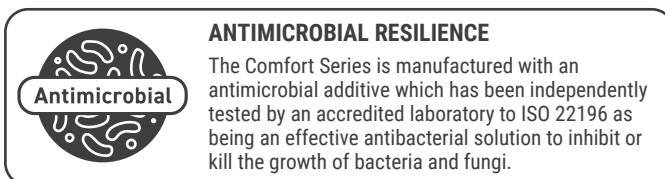

TECHNICAL DATA

PART NUMBER	CSW1DP16WH
DESCRIPTION	Comfort Switch Mech 1 Gang, 2-Way, Double Pole, 16A, White
SUPPLY VOLTAGE	230-240Va.c.
CURRENT RATING	16A
COLOUR	White
MOUNTING CENTRE	N/A
PLATE SIZE	N/A
SWITCH SIZE	48.5mm x 48.5mm
COMPLIANCE	AS/NZS 3133, ISO 22196, AS 1428.1 - Design for access and mobility, Livable Housing Design Guidelines – Switches & Powerpoints (Platinum Level)

DIMENSIONS

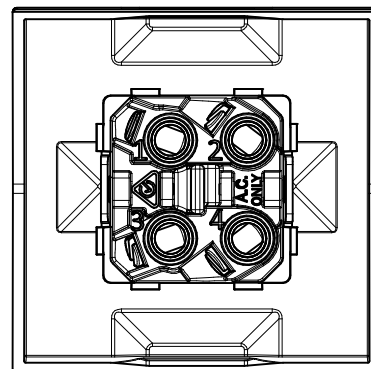
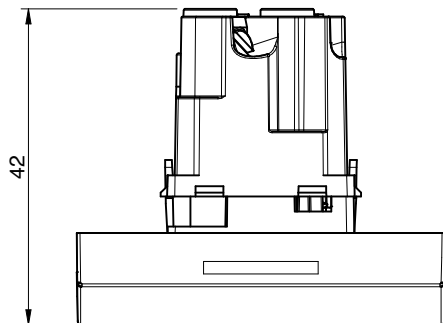
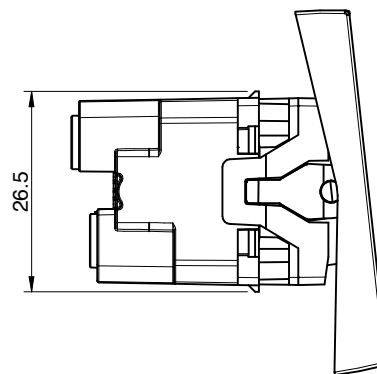
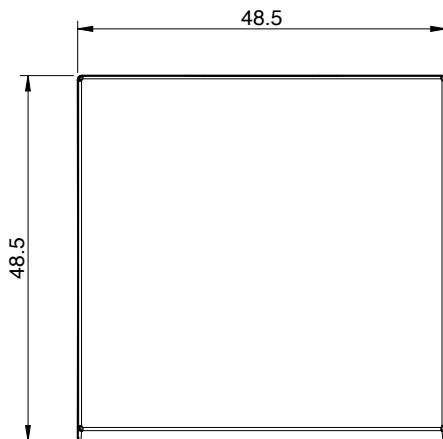

esco
industries

THE ESCO GROUP OF COMPANIES

esco industries MASRAP MediTek

modempak

ESCO INDUSTRIES

89 Egerton St (Cnr Fariola & Egerton)
PO Box 6193, Silverwater
NSW 2128 AUSTRALIA

T 1300 879 363 F 1300 879 364

customer.service@escoindustries.com.au
www.escoindustries.com.au

MODEMPAK NZ

Unit 11/273 Neilson St, Onehunga
AUCKLAND 1061 NEW ZEALAND

D +64 9 526 1880 Freecall 0800 663 367

customer.service@modempak.co.nz
www.modempak.co.nz

PART NUMBER

CSW1INT16WH

MODEL DESCRIPTION

Comfort Switch Mech 1 Gang, Intermediate, 16A, White



ANTIMICROBIAL RESILIENCE

The Comfort Series is manufactured with an antimicrobial additive which has been independently tested by an accredited laboratory to ISO 22196 as being an effective antibacterial solution to inhibit or kill the growth of bacteria and fungi.

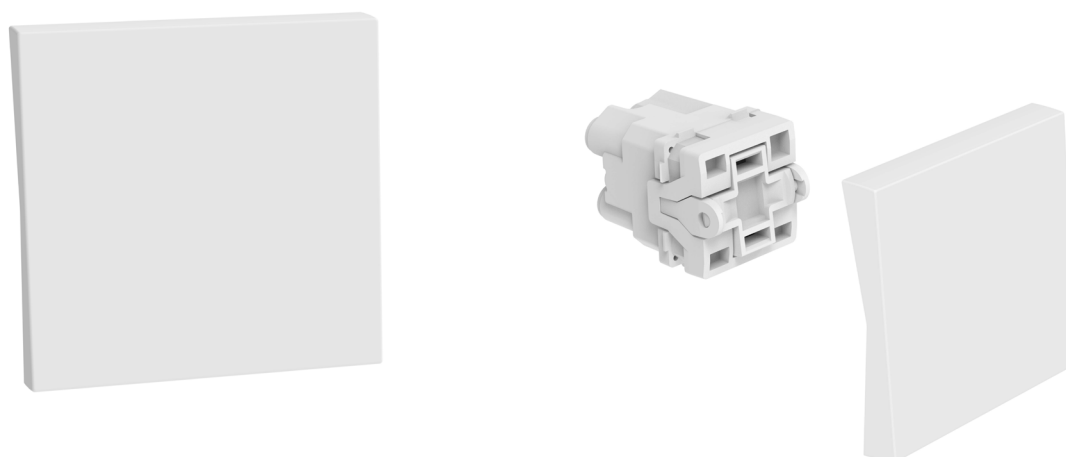

TECHNICAL DATA

PART NUMBER	CSW1INT16WH
DESCRIPTION	Comfort Switch Mech 1 Gang, Intermediate, 16A, White
SUPPLY VOLTAGE	230-240Va.c.
CURRENT RATING	16A
COLOUR	White
MOUNTING CENTRE	N/A
PLATE SIZE	N/A
SWITCH SIZE	48.5mm x 48.5mm
COMPLIANCE	AS/NZS 3133, ISO 22196, AS 1428.1 - Design for access and mobility, Livable Housing Design Guidelines – Switches & Powerpoints (Platinum Level)

DIMENSIONS

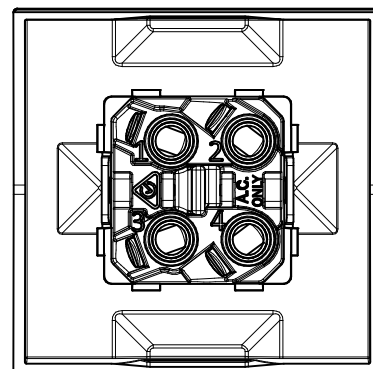
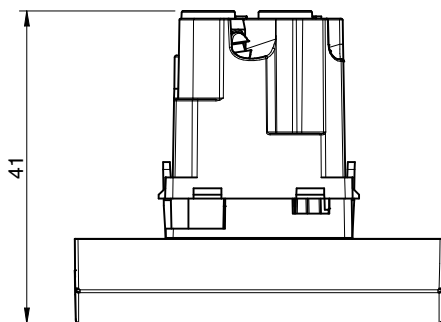
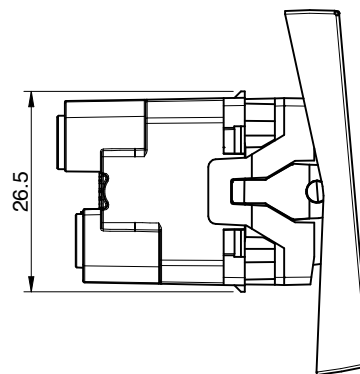
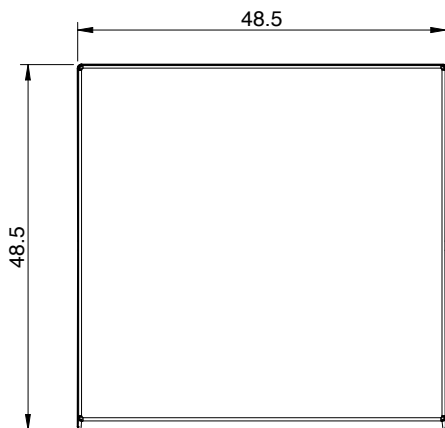

esco
industries

THE ESCO GROUP OF COMPANIES

esco industries MASRAP **MediTek**

modempak

ESCO INDUSTRIES

89 Egerton St (Cnr Fariola & Egerton)
PO Box 6193, Silverwater
NSW 2128 AUSTRALIA

T 1300 879 363 F 1300 879 364

customer.service@escoindustries.com.au
www.escoindustries.com.au

MODEMPAK NZ

Unit 11/273 Neilson St, Onehunga
AUCKLAND 1061 NEW ZEALAND

D +64 9 526 1880 **Freecall** 0800 663 367

customer.service@modempak.co.nz
www.modempak.co.nz

PART NUMBER

CSWPBWH

MODEL DESCRIPTION

Comfort Switch Mech 1 Gang, Momentary Push Button marked PRESS,16A, White

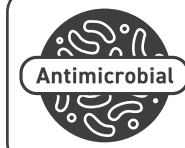

ANTIMICROBIAL RESILIENCE

The Comfort Series is manufactured with an antimicrobial additive which has been independently tested by an accredited laboratory to ISO 22196 as being an effective antibacterial solution to inhibit or kill the growth of bacteria and fungi.



TECHNICAL DATA

PART NUMBER	CSWPBWH
DESCRIPTION	Comfort Switch Mech 1 Gang, Momentary Push Button marked PRESS,10A, White
SUPPLY VOLTAGE	230-240Va.c.
CURRENT RATING	16A
COLOUR	White
MOUNTING CENTRE	N/A
PLATE SIZE	N/A
SWITCH SIZE	48.5mm x 48.5mm
COMPLIANCE	AS/NZS 3133, ISO 22196, AS 1428.1 - Design for access and mobility, Livable Housing Design Guidelines – Switches & Powerpoints (Platinum Level)

DIMENSIONS

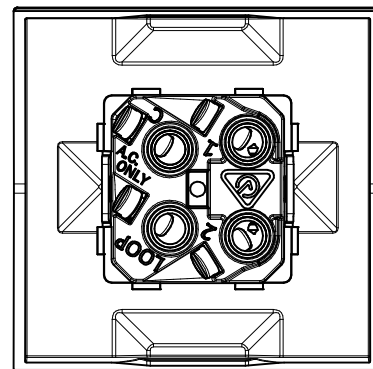
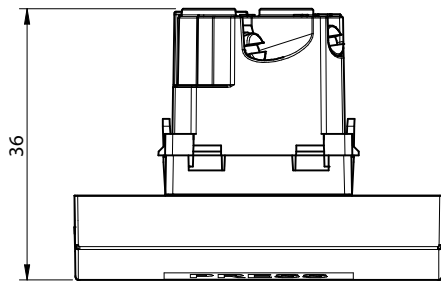
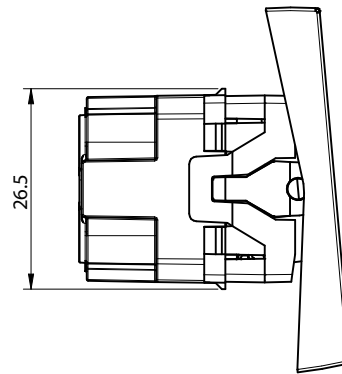
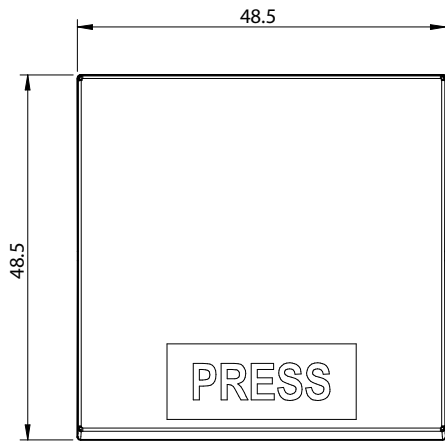

esco
industries

THE ESCO GROUP OF COMPANIES

esco industries MASRAP MediTek

modempak

ESCO INDUSTRIES

89 Egerton St (Cnr Fariola & Egerton)
PO Box 6193, Silverwater
NSW 2128 AUSTRALIA

T 1300 879 363 F 1300 879 364

customer.service@escoindustries.com.au
www.escoindustries.com.au

MODEMPAK NZ

Unit 11/273 Neilson St, Onehunga
AUCKLAND 1061 NEW ZEALAND

D +64 9 526 1880 Freecall 0800 663 367

customer.service@modempak.co.nz
www.modempak.co.nz

PART NUMBER

CBMWH

MODEL DESCRIPTION

Blank Mechanism, White

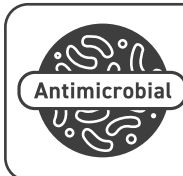

ANTIMICROBIAL RESILIENCE

The Comfort Series is manufactured with an antimicrobial additive which has been independently tested by an accredited laboratory to ISO 22196 as being an effective antibacterial solution to inhibit or kill the growth of bacteria and fungi.



TECHNICAL DATA

PART NUMBER	CBMWH
DESCRIPTION	Blank Mechanism, White
SUPPLY VOLTAGE	N/A
CURRENT RATING	N/A
COLOUR	White
MOUNTING CENTRE	N/A
PLATE SIZE	N/A
COMPLIANCE	ISO 22196

DIMENSIONS

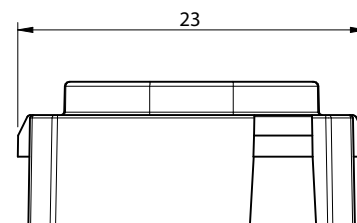
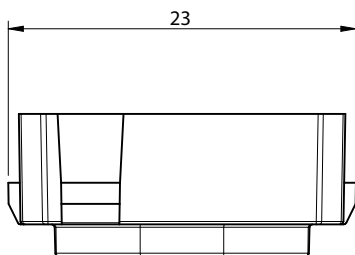
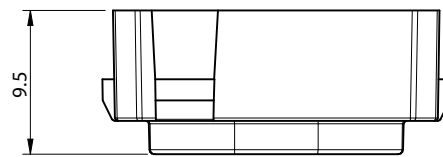
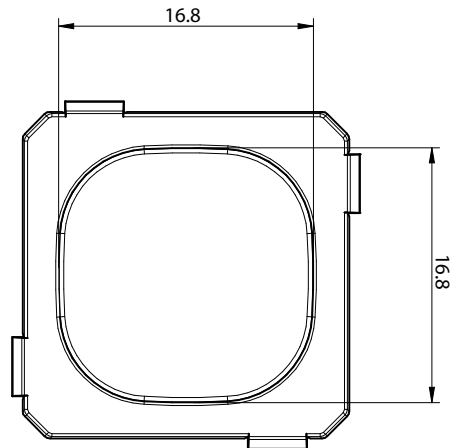

esco
industries

THE ESCO GROUP OF COMPANIES

esco industries MASRAP MediTek

modempak

ESCO INDUSTRIES

89 Egerton St (Cnr Fariola & Egerton)
PO Box 6193, Silverwater
NSW 2128 AUSTRALIA

T 1300 879 363 F 1300 879 364

customer.service@escoindustries.com.au
www.escoindustries.com.au

MODEMPAK NZ

Unit 11/273 Neilson St, Onehunga
AUCKLAND 1061 NEW ZEALAND

D +64 9 526 1880 Freecall 0800 663 367

customer.service@modempak.co.nz
www.modempak.co.nz