

## PART NUMBER

**CS1VWH**

## MODEL DESCRIPTION

Socket Outlet, Switched, 10A, Vertical, White



**ANTIMICROBIAL RESILIENCE**

The Comfort Series is manufactured with an antimicrobial additive which has been independently tested by an accredited laboratory to ISO 22196 as being an effective antibacterial solution to inhibit or kill the growth of bacteria and fungi.



## TECHNICAL DATA

<b>PART NUMBER</b>	CS1VWH
<b>DESCRIPTION</b>	Socket Outlet, Switched, 10A, Vertical, White
<b>SUPPLY VOLTAGE</b>	250Va.c.
<b>CURRENT RATING</b>	10A
<b>COLOUR</b>	White
<b>MOUNTING CENTRE</b>	84mm
<b>PLATE SIZE</b>	Standard
<b>SWITCH SIZE</b>	48.5mm x 48.5mm
<b>COMPLIANCE</b>	AS/NZS3133, AS/NZS3112, ISO 22196, AS 1428.1 - Design for access and mobility, Livable Housing Design Guidelines – Switches & Powerpoints (Platinum Level)

## DIMENSIONS

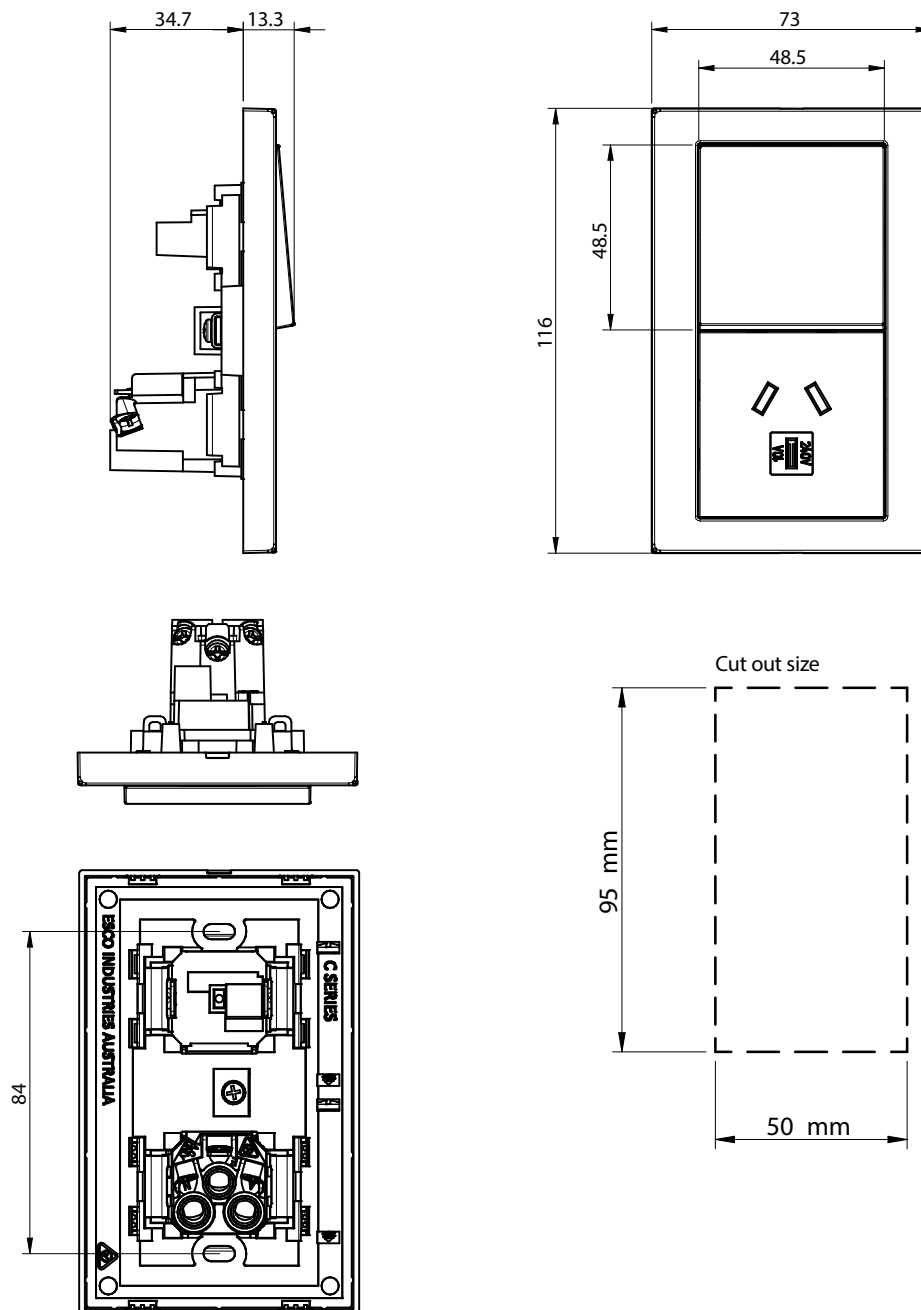

**esco**  
**industries**

THE ESCO GROUP OF COMPANIES

**esco** industries MASRAP **MediTek**

modempak

**ESCO INDUSTRIES**

89 Egerton St (Cnr Fariola & Egerton)  
 PO Box 6193, Silverwater  
 NSW 2128 AUSTRALIA

**MODEMPAK NZ**

30 Fairfax Ave, Penrose  
 AUCKLAND 1642 NEW ZEALAND

T 1300 879 363 F 1300 879 364

customer.service@escoindustries.com.au  
 www.escoindustries.com.au

D +64 9 526 1880 **Freecall** 0800 663 367

F +64 9 580 0606  
 customer.service@modempak.co.nz  
 www.modempak.co.nz

## PART NUMBER

**CS1LVWH**

## MODEL DESCRIPTION

Socket Outlet, Switched, with red LED 'ON' indicator, 10A, Vertical, White

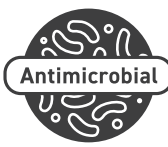

**ANTIMICROBIAL RESILIENCE**

The Comfort Series is manufactured with an antimicrobial additive which has been independently tested by an accredited laboratory to ISO 22196 as being an effective antibacterial solution to inhibit or kill the growth of bacteria and fungi.



## TECHNICAL DATA

<b>PART NUMBER</b>	CS1LVWH
<b>DESCRIPTION</b>	Socket Outlet, Switched, with red LED 'ON' indicator, 10A, Vertical, White
<b>SUPPLY VOLTAGE</b>	250Va.c.
<b>CURRENT RATING</b>	10A
<b>COLOUR</b>	White
<b>MOUNTING CENTRE</b>	84mm
<b>PLATE SIZE</b>	Standard
<b>SWITCH SIZE</b>	48.5mm x 48.5mm
<b>COMPLIANCE</b>	AS/NZS3133, AS/NZS3112, ISO 22196, AS 1428.1 - Design for access and mobility, Livable Housing Design Guidelines – Switches & Powerpoints (Platinum Level)

## DIMENSIONS

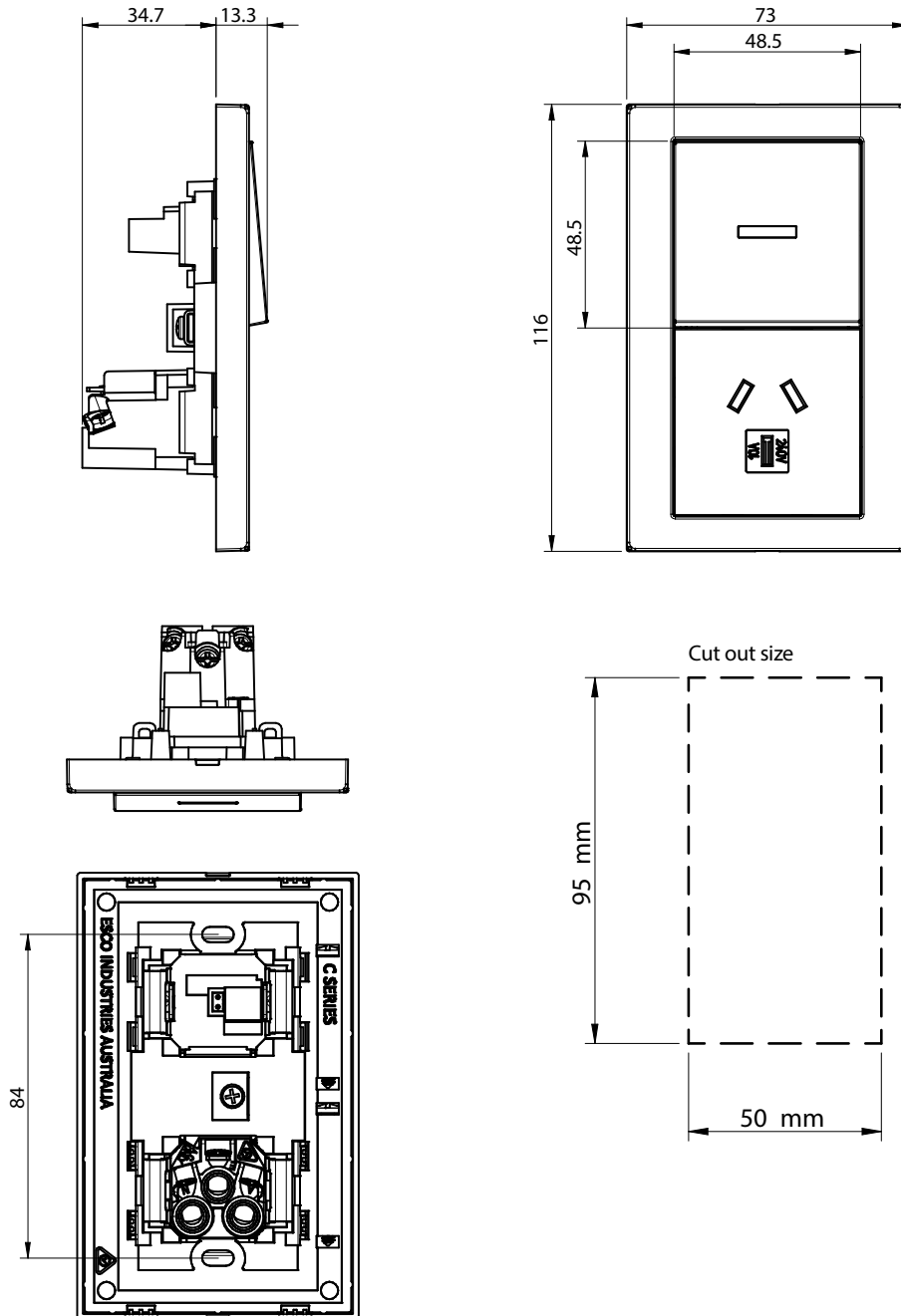

**esco**  
industries

THE ESCO GROUP OF COMPANIES

esco industries MASRAP **MediTek**

modempak

**ESCO INDUSTRIES**

89 Egerton St (Cnr Fariola & Egerton)  
PO Box 6193, Silverwater  
NSW 2128 AUSTRALIA

**MODEMPAK NZ**

30 Fairfax Ave, Penrose  
AUCKLAND 1642 NEW ZEALAND

T 1300 879 363 F 1300 879 364

customer.service@escoindustries.com.au  
www.escoindustries.com.au

D +64 9 526 1880 **Freecall** 0800 663 367

F +64 9 580 0606  
customer.service@modempak.co.nz  
www.modempak.co.nz