

## **PART NUMBER**

# **CSWP1V16WH**

## **MODEL DESCRIPTION**

Comfort Switch 1 Gang, 2-Way, 16A, Vertical, White

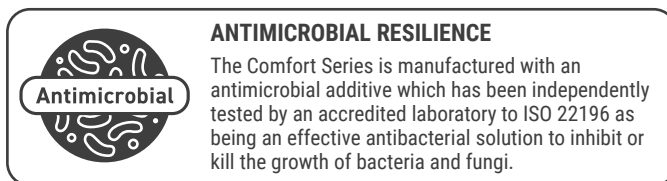

## **TECHNICAL DATA**

|                        |   |
|------------------------|---|
| <b>PART NUMBER</b>     | CSWP1V16WH  |
| <b>DESCRIPTION</b>     | Comfort Switch 1 Gang, 2-Way, 16A, Vertical, White  |
| <b>SUPPLY VOLTAGE</b>  | 230-240Va.c.  |
| <b>CURRENT RATING</b>  | 16A   |
| <b>COLOUR</b>          | White   |
| <b>MOUNTING CENTRE</b> | 84mm  |
| <b>PLATE SIZE</b>      | Standard  |
| <b>SWITCH SIZE</b>     | 48.5mm x 48.5mm   |
| <b>COMPLIANCE</b>      | AS/NZS 3133, ISO 22196, AS 1428.1 - Design for access and mobility, Livable Housing Design Guidelines – Switches & Powerpoints (Platinum Level) |

## DIMENSIONS

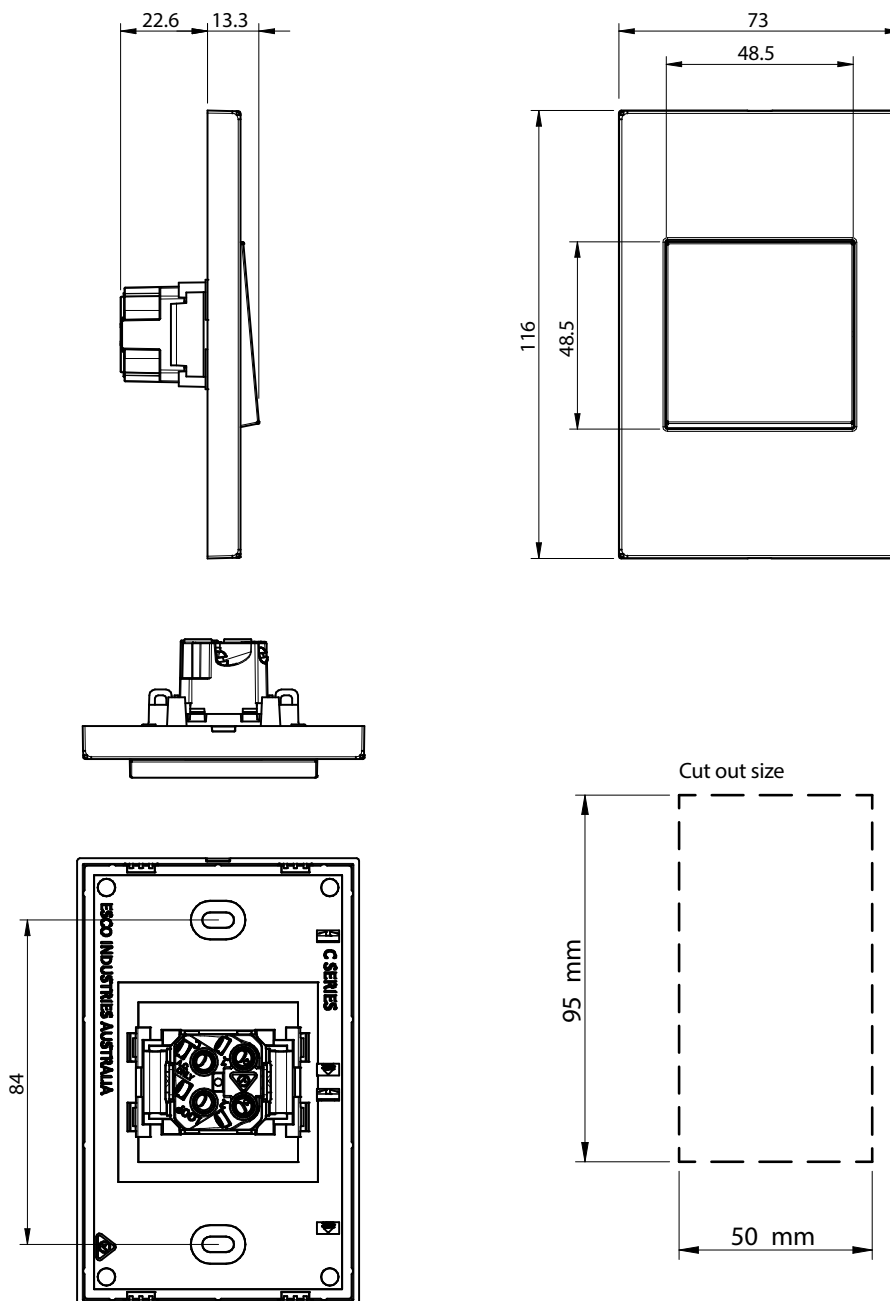

**esco**  
industries

THE ESCO GROUP OF COMPANIES

esco industries MASRAP **MediTek**

modempak

**ESCO INDUSTRIES**

89 Egerton St (Cnr Fariola & Egerton)  
PO Box 6193, Silverwater  
NSW 2128 AUSTRALIA

**MODEMPAK NZ**

Unit 11/273 Neilson St, Onehunga  
AUCKLAND 1061 NEW ZEALAND

T 1300 879 363 F 1300 879 364

customer.service@escoindustries.com.au  
www.escoindustries.com.au

D +64 9 526 1880 **Freecall** 0800 663 367

customer.service@modempak.co.nz  
www.modempak.co.nz

## PART NUMBER

# CSWP1VL16WH

## MODEL DESCRIPTION

Comfort Switch 1 Gang, 2-Way, with red LED 'ON' indicator, 16A, Vertical, White

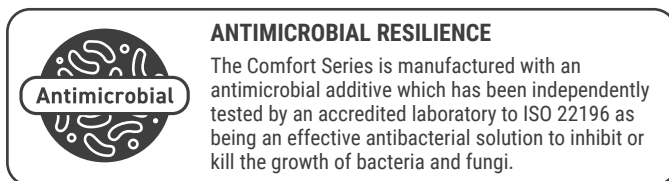

## TECHNICAL DATA

|                        |   |
|------------------------|---|
| <b>PART NUMBER</b>     | CSWP1VL16WH   |
| <b>DESCRIPTION</b>     | Comfort Switch 1 Gang, 2-Way, with red LED 'ON' indicator, 16A, Vertical, White   |
| <b>SUPPLY VOLTAGE</b>  | 230-240Va.c.  |
| <b>CURRENT RATING</b>  | 16A   |
| <b>COLOUR</b>          | White   |
| <b>MOUNTING CENTRE</b> | 84mm  |
| <b>PLATE SIZE</b>      | Standard  |
| <b>SWITCH SIZE</b>     | 48.5mm x 48.5mm   |
| <b>COMPLIANCE</b>      | AS/NZS 3133, ISO 22196, AS 1428.1 - Design for access and mobility, Livable Housing Design Guidelines – Switches & Powerpoints (Platinum Level) |

## DIMENSIONS

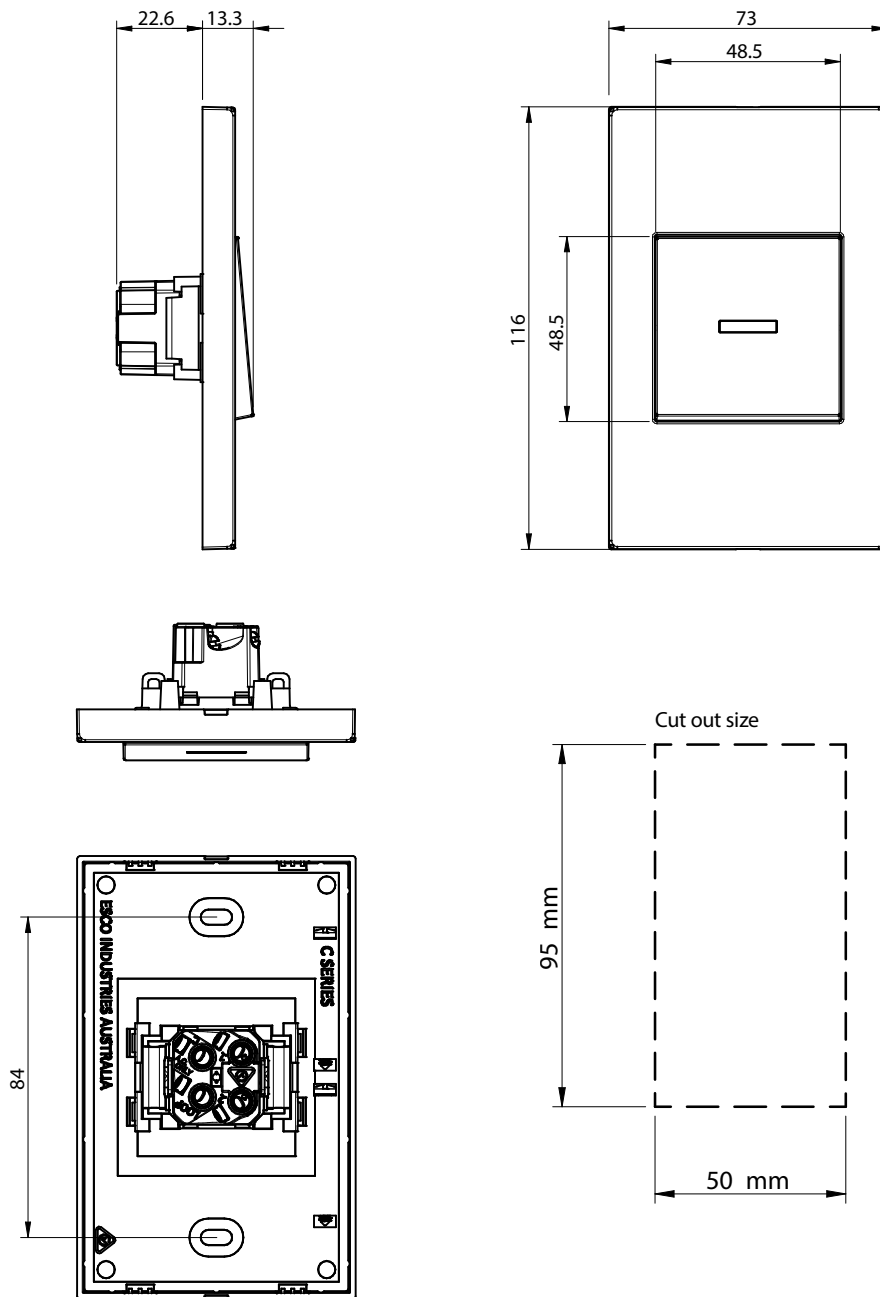

**esco**  
industries

THE ESCO GROUP OF COMPANIES

esco industries MASRAP **MediTek**

modempak

**ESCO INDUSTRIES**

89 Egerton St (Cnr Fariola & Egerton)  
PO Box 6193, Silverwater  
NSW 2128 AUSTRALIA

T 1300 879 363 F 1300 879 364

customer.service@escoindustries.com.au  
www.escoindustries.com.au

**MODEMPAK NZ**

Unit 11/273 Neilson St, Onehunga  
AUCKLAND 1061 NEW ZEALAND

D +64 9 526 1880 **Freecall** 0800 663 367

customer.service@modempak.co.nz  
www.modempak.co.nz

## **PART NUMBER**

# **CSWP2V16WH**

## **MODEL DESCRIPTION**

Comfort Switch 2 Gang, 2-Way, 16A, Vertical, White

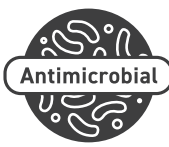

**ANTIMICROBIAL RESILIENCE**

The Comfort Series is manufactured with an antimicrobial additive which has been independently tested by an accredited laboratory to ISO 22196 as being an effective antibacterial solution to inhibit or kill the growth of bacteria and fungi.



## **TECHNICAL DATA**

|                        |   |
|------------------------|---|
| <b>PART NUMBER</b>     | CSWP2V16WH  |
| <b>DESCRIPTION</b>     | Comfort Switch 2 Gang, 2-Way, 16A, Vertical, White  |
| <b>SUPPLY VOLTAGE</b>  | 230-240Va.c.  |
| <b>CURRENT RATING</b>  | 16A   |
| <b>COLOUR</b>          | White   |
| <b>MOUNTING CENTRE</b> | 84mm  |
| <b>PLATE SIZE</b>      | Standard  |
| <b>SWITCH SIZE</b>     | 48.5mm x 48.5mm   |
| <b>COMPLIANCE</b>      | AS/NZS 3133, ISO 22196, AS 1428.1 - Design for access and mobility, Livable Housing Design Guidelines – Switches & Powerpoints (Platinum Level) |

## DIMENSIONS

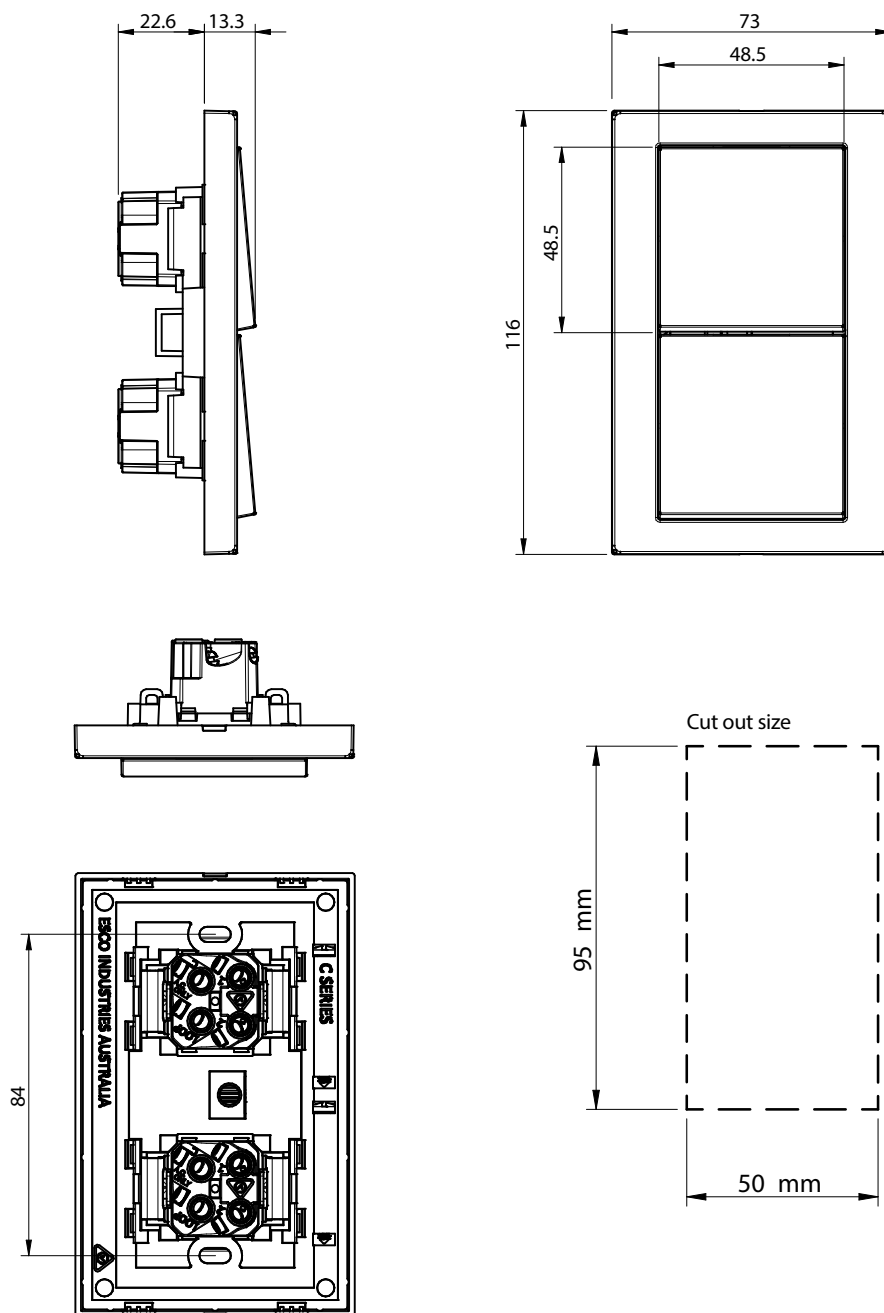

**esco**  
industries

THE ESCO GROUP OF COMPANIES

esco industries MASRAP **MediTek**

modempak

**ESCO INDUSTRIES**

89 Egerton St (Cnr Fariola & Egerton)  
PO Box 6193, Silverwater  
NSW 2128 AUSTRALIA

**MODEMPAK NZ**

Unit 11/273 Neilson St, Onehunga  
AUCKLAND 1061 NEW ZEALAND

T 1300 879 363 F 1300 879 364

customer.service@escoindustries.com.au  
www.escoindustries.com.au

D +64 9 526 1880 Freecall 0800 663 367

customer.service@modempak.co.nz  
www.modempak.co.nz

## PART NUMBER

# CSWP2VL16WH

## MODEL DESCRIPTION

Comfort Switch 2 Gang, 2-Way, with red LED 'ON' indicator, 16A, Vertical, White

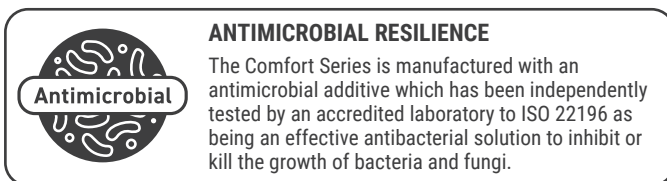

## TECHNICAL DATA

|                        |   |
|------------------------|---|
| <b>PART NUMBER</b>     | CSWP2VL16WH   |
| <b>DESCRIPTION</b>     | Comfort Switch 2 Gang, 2-Way, with red LED 'ON' indicator, 16A, Vertical, White   |
| <b>SUPPLY VOLTAGE</b>  | 230-240Va.c.  |
| <b>CURRENT RATING</b>  | 16A   |
| <b>COLOUR</b>          | White   |
| <b>MOUNTING CENTRE</b> | 84mm  |
| <b>PLATE SIZE</b>      | Standard  |
| <b>SWITCH SIZE</b>     | 48.5mm x 48.5mm   |
| <b>COMPLIANCE</b>      | AS/NZS 3133, ISO 22196, AS 1428.1 - Design for access and mobility, Livable Housing Design Guidelines – Switches & Powerpoints (Platinum Level) |

## DIMENSIONS

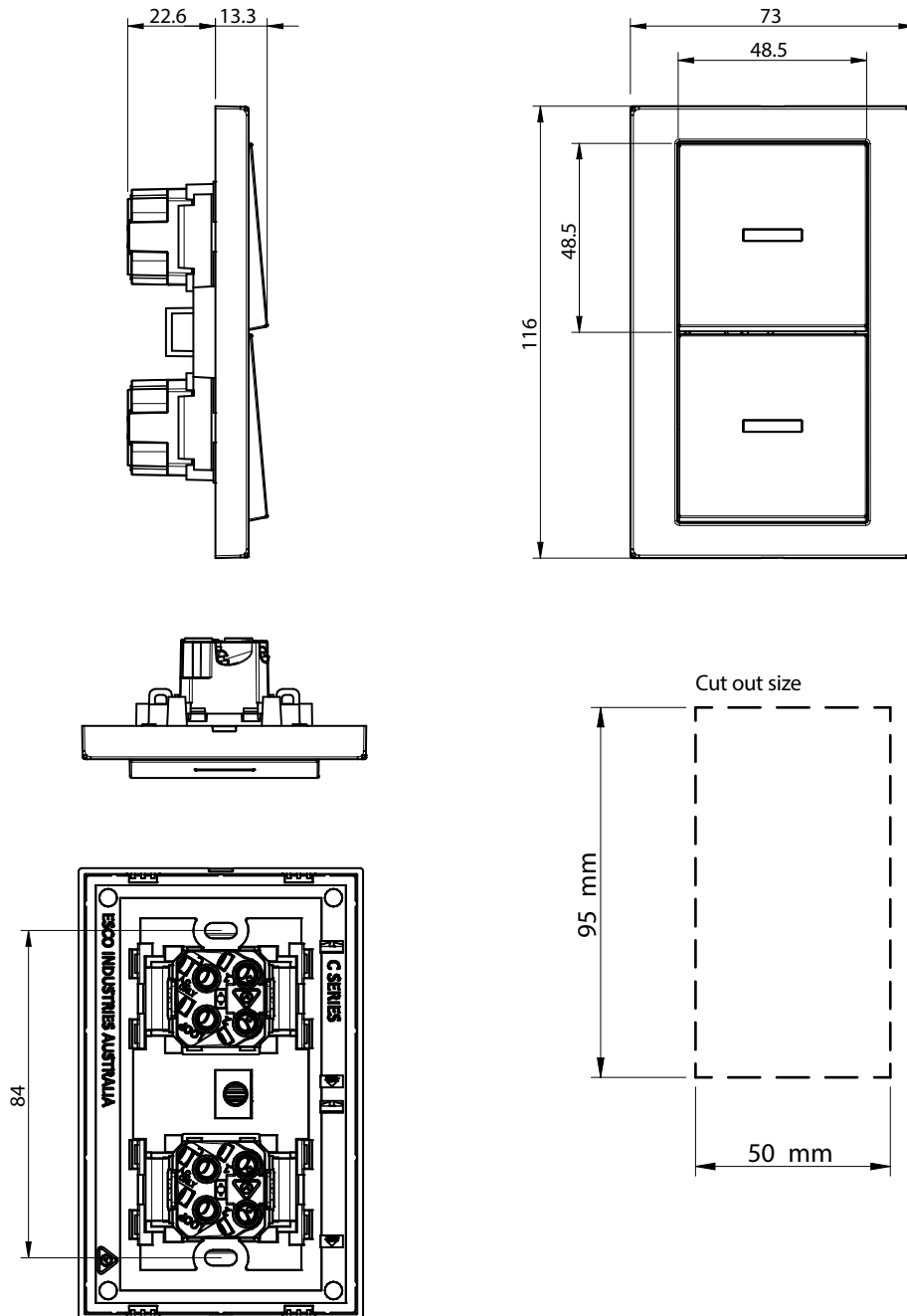

**esco**  
industries

THE ESCO GROUP OF COMPANIES

esco industries MASRAP **MediTek**

modempak

**ESCO INDUSTRIES**

89 Egerton St (Cnr Fariola & Egerton)  
PO Box 6193, Silverwater  
NSW 2128 AUSTRALIA

**MODEMPAK NZ**

Unit 11/273 Neilson St, Onehunga  
AUCKLAND 1061 NEW ZEALAND

T 1300 879 363 F 1300 879 364

customer.service@escoindustries.com.au  
www.escoindustries.com.au

D +64 9 526 1880 Freecall 0800 663 367

customer.service@modempak.co.nz  
www.modempak.co.nz